

# TRANSMETRA

Messtechnik mit KnowHow.

# User Manual

FOTRIC 600 Series

Fixed-mount infrared camera

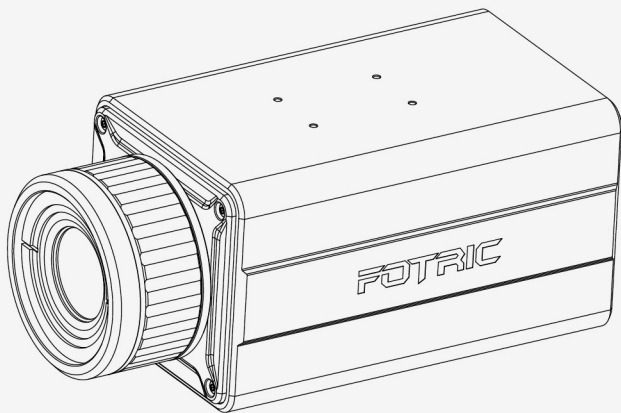

# FOTRIC

— Beyond the limit of Sight —

# Contents

<b>Legal Disclaimer</b> .....	<b>1</b>
1.1 Legal Disclaimer .....	1
1.2 Usage Statistics .....	2
1.3 Copyright .....	3
1.4 Quality Assurance .....	3
1.5 Export Control .....	4
<b>Safety Information</b> .....	<b>5</b>
<b>Thermal Camera</b> .....	<b>9</b>
Overview .....	9
Manual Focus Model Schematics .....	10
Auto Focus Model Schematics .....	12
Rear Interface Schematic .....	18
Mounting Holes .....	20
<b>IP Address Setting</b> .....	<b>21</b>
<b>FAQs</b> .....	<b>23</b>
<b>Read Before Using:</b> .....	<b>26</b>
<b>Software Download</b> .....	<b>26</b>
<b>Appendix</b> .....	<b>27</b>

# Legal Disclaimer

## 1.1 Legal Disclaimer

Uncooled thermal imaging manufactured by FOTRIC are entitled to 1-2-years warranty (depending on the specific model) from the date of initial purchase and delivery. Warranty covers defects caused by materials and production processes, provided that such products are handled under normal storage, use, and repair conditions and in accordance with FOTRIC instructions.

Products not manufactured by FOTRIC but included in the system that FOTRIC sells to the original purchaser are covered by the specific supplier's warranty terms (if any) and FOTRIC is not liable for those products. This warranty is provided to the original purchaser and is not transferable. This warranty does not apply to any product that has been damaged by misuse, neglect, accident, or abnormal operating conditions. Consumable parts are not covered by this warranty.

Any defects in the products covered by this warranty must be reported and the product must not be used to prevent further damage. The purchaser must report any defects to FOTRIC immediately, otherwise this warranty will not apply.

If the product is proven defective in relation to materials or manufacturing after FOTRIC's inspection, it is up to the user whether it is to be repaired free of charge or replaced, provided that the product must be returned to FOTRIC within 3 Months from above mentioned report date. FOTRIC has no obligation or liability for any defects other than those mentioned above. This product is exempt from any other warranties, expressed or implied. FOTRIC hereby disclaims any implied warranties of merchantability and applicability for a particular purpose. FOTRIC is not responsible for any direct, indirect, special, incidental or consequential loss or damage based on contract, civil, or any other legal theory. This warranty clause shall apply the relevant provisions of the laws of the People's Republic of China. Any dispute or claim arising out of or related to this warranty shall be finally settled through arbitration in accordance with the rules of the Shanghai Pudong New District People's Court of the People's Republic of China. The place of arbitration shall be Shanghai.

## **1.2 Usage Statistics**

FOTRIC reserves the right to collect anonymous usage statistics to help maintain and improve the quality of the software and services provided.

### **1.3 Copyright**

No parts of this software (including source code) may be reproduced, transmitted, transcribed, or translated into any kind of language or computer language in any form or by electronic, electromagnetic, optical, manual ways, or any other means without the prior written permission of FOTRIC.

No parts of this document may be reproduced, photocopied, reprinted, translated, or transmitted to any readable electronic medium or machine without the prior written consent of FOTRIC.

The names and logos shown on the products herein are either registered trademarks or trademarks of FOTRIC and/or its affiliates. All other trademarks, trade names or company names referenced herein are for identification purposes only and are the property of their respective owners.

### **1.4 Quality Assurance**

The quality management system for the development and production of these products in FOTRIC has been certified in accordance with the ISO 9001 standard.

FOTRIC is committed to a policy of continuous development, so we reserve the right to modify or improve

any product without prior notice.

### **1.5 Export Control**

Thermal imaging products are listed as export-controlled products by the U.S. Department of Commerce, United Nations Security Council (UNSC), and European Union (EU). This product contains a focal plane array and cannot be used in controlled countries (such as North Korea, Iran, Syria, Cuba, Sudan, etc.), so please do not bring this product into or used in controlled countries. Any loss or liability arising from the above actions will be borne by you.

# Safety Information

This product complies with the restrictions for Class A digital equipment in Chapter 15 of the FCC Rules. These restrictions are designed to provide reasonable protection against harmful interference in a residential installation. If not installed and used in accordance with instructions, this equipment may cause personnel injury or property loss. Please maintain this user manual in safe condition for future reference.

## Definition



! Warning > Represents a hazardous situation or behavior that could result in potential personnel serious injury or death.



! Caution > Represents conditions or actions that could result in potential personnel injury or property loss.

## **Warning!**

- Please use power source that complies with SELV (Separated Extra Low Voltage), and rated 12V/24V power supply which meets the standards of Limited Power Source according to IEC60950-1.
- If the product does not work properly, please contact your local distributor or FOTRIC service center immediately. Fotric shall not bear the responsibility for any damage which caused by improper use, improper maintenance, unauthorized repair or disassembly of equipment.
- In order to reduce the risk of fire accident or electric shock, please keep the indoor products in rain/waterproof and avoid moisture.
- The installation of this product shall be carried out or conducted by professional service personnel, and comply with local regulations.
- Easy-to-use power-off equipment is recommended to incorporate into building's installation wirings.



## Caution!

- Please check the power supply carefully before connect to the thermal camera.
- Please protect the product from drop to ground or strong shock.
- Please do not touch directly on the lens. If necessary, Use a soft cloth and pure water/Non-irritant cleaning liquid to clean gently. When the thermal imager is not in use, store it in a clean environment to protect it from dust.
- Please do not point the infrared camera (with or without the lens cover) at strong energy sources or the sun, otherwise it may cause an unwanted effect on the accuracy of the camera, or even permanently damage the IR detector.
- Please do not place the thermal camera on humid, dusty, extremely hot, extremely cold (working temperature  $-20\sim 50^{\circ}\text{C}$  ), and strong electromagnetic radiation filed.
- Please keeps installation position enough distance away from the surrounded electromagnetic sensitive equipment, to avoid possible electromagnetic interference.

- Please ensure enough installation space to maintain ventilation around the thermal imager.
- Original packing box is highly recommended to be kept during transportation. Please avoid strong impact on the packing during transportation.

# Thermal Camera

## Overview

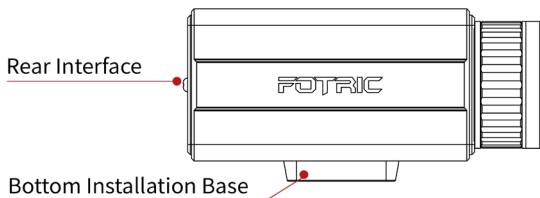
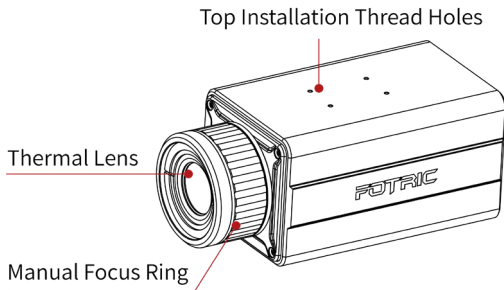

## Manual Focus Model Schematics

(unit: mm)

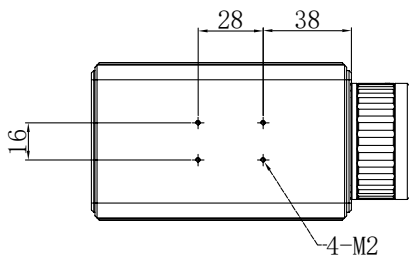
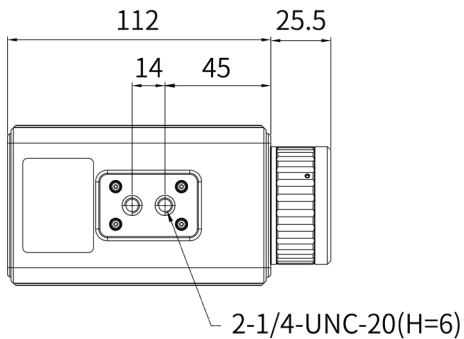

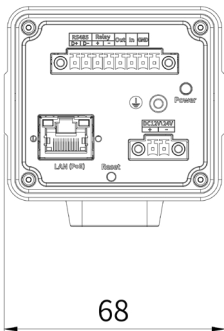
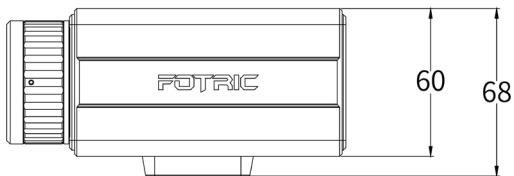

## Auto Focus Model Schematics

(unit: mm)

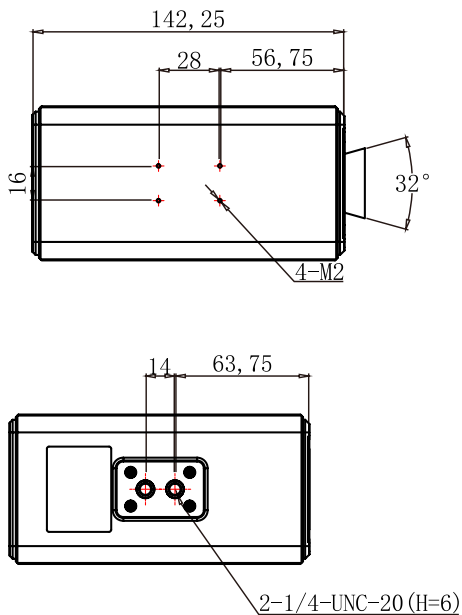

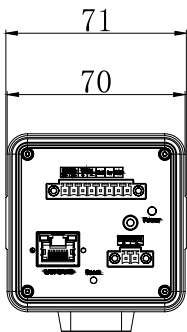
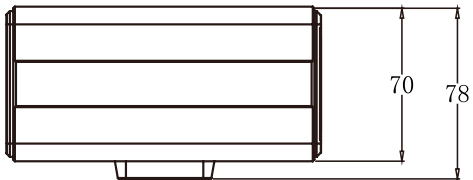

## Auto Focus Model Schematics

High temperature expansion FOTRIC 626CH

(unit: mm)

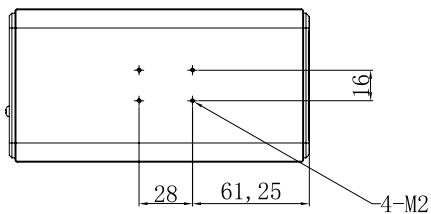
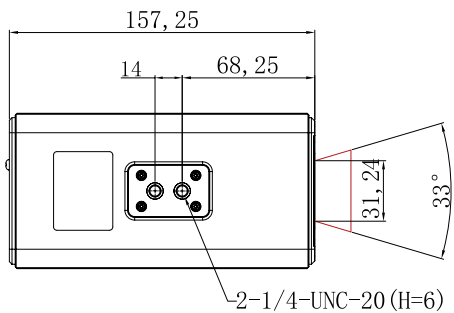



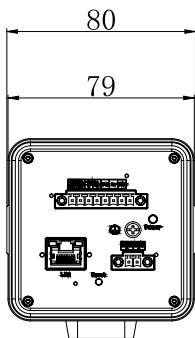
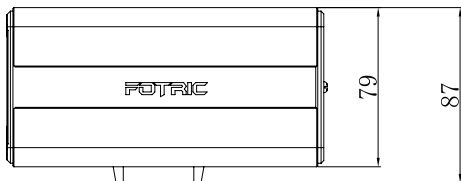

## Auto Focus Model Schematics

High temperature expansion FOTRIC 628CH

(unit: mm)

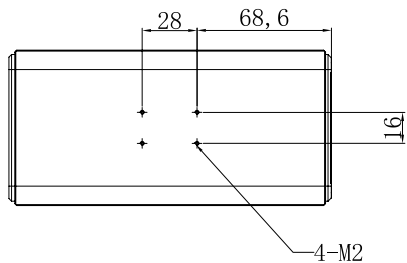
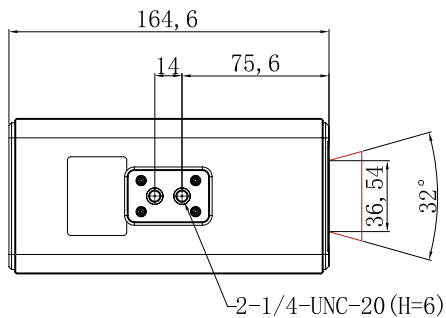

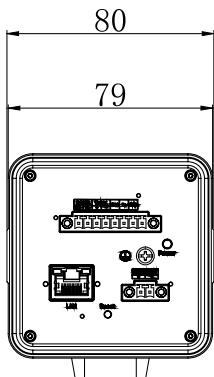

## Rear Interface Schematic

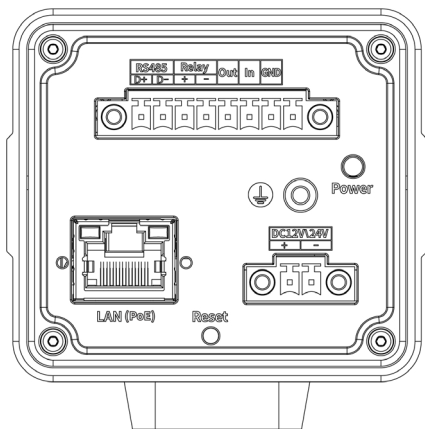

Power supply	+	DC12/24VDC										
	-											
	Ground											
RS485	A	<table border="1"> <tr> <th colspan="2">Rs485</th> </tr> <tr> <td>Protocol</td> <td>Pelco-D</td> </tr> <tr> <td>Baud rate</td> <td>9600</td> </tr> <tr> <td>Address code</td> <td>1</td> </tr> <tr> <td>Parity bit</td> <td>N/A</td> </tr> </table>	Rs485		Protocol	Pelco-D	Baud rate	9600	Address code	1	Parity bit	N/A
	Rs485											
Protocol	Pelco-D											
Baud rate	9600											
Address code	1											
Parity bit	N/A											
B												
Relay	+	Electric relay 3.3-24V, 1.5A										
	-											
Out	—	Optocoupler output, 3.3-24V, Output current 50mA										
In	—	Optocoupler input, 3.3-24V, Input current, 5mA~15mA										
GND	—	Ground line										
Power	—	Power indicator										
Reset	Reset to factory default	IP address reset to 192.168.1.100										
LAN (PoE)	RJ45 network port	Gigabit ethernet port										

Note:

For specified parameters please refer to product datasheet.

## Mounting Holes

(unit: mm)

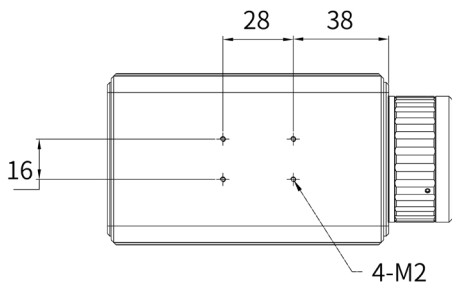
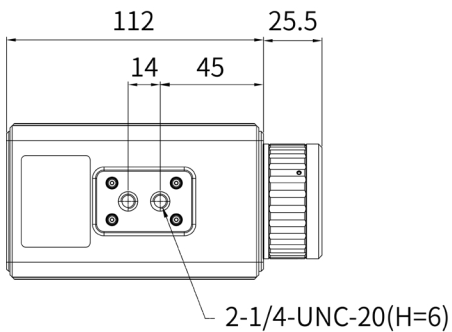

# IP Address Setting

Please follow the procedures below:

Please connect the thermal camera to 12V / 24V DC power supply.

1. Connect the camera's RJ45 Network Port with Net cable to the server/computer.
2. Set the Server's IP address to the same network segment. The camera's default IP is 192.168.1.100

Note: The server's IP address must not conflict with the camera.

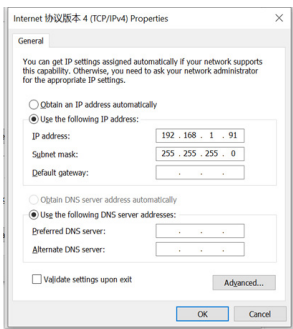

Computer's IP configuration interface

3. To search the thermal camera's IP address, visit FOTRIC official website:  
  
**[www.fotric.com/support-ipconfig](http://www.fotric.com/support-ipconfig)** to download and Install IPConfig software.
4. Open IPConfig software and click “Reload” . Select the target camera, and click “Auto Acquire” .
5. Open a FOTRIC SDK based software (or alternatively the FOTRIC AnalyzIR), input the IP address, and connect to the thermal camera.
6. Manually or mechanically adjust the focus range of thermal camera, to make sure the object is in clear focus.
7. Ensure the temperature range and other parameters are correct, start video streaming.

Note:

Focus range is very important for thermal cameras. Wrong focus range adjustment will affect camera's imaging quality and measurement accuracy.



## FAQs

Q:

Why is the IP address not found, after the thermal camera is powered on and connected?

A:

Firstly, please make sure that the Power green indicator and the Network port flash indicators are on. The thermal camera may need about 1 to 2 minutes to initialize settings.

Secondly, please make sure that the Server/Computer's IP address are in the same network segment and do not conflict with thermal camera.

Q:

What might have caused the measurement results to be obviously erroneous?

A:

Please check the following parameters settings:

- Lens type and lens parameter settings

- Emissivity settings
- Focus range choice
- The camera is not yet warmed up (10~15 minutes)
- Temperature measurement range choice
- NUC mode settings (we recommend auto NUC calibration)
- Other parameters setting, such as IR window transmission, environment temperature, distance, etc.

Q:

Why does the software not display any video stream or image?

A:

Check if the server/computer's firewall is turned off. If not, please turn off the firewall, and then restart the Computer and the thermal camera.

Check if your PC software is updated to newest version.  
Please visit FOTRIC website **[www.fotric.com/support-analyzir](http://www.fotric.com/support-analyzir)** to download.

If the solutions above are still not working, please consult your local distributor, or contact Fotric directly.

*Due to any possible product design upgrade or new product types, Please always refer to the specific product.*

## Read Before Using:

Manuals download:

Before using the product, please visit the following website to download the manuals:

FOTRIC 600 Series:

**<https://www.fotric.com/support-fotric600>**

## Software Download

PC software AnalyzIR is the standard software for the product.

Please visit the following website to download it and its user manual:

**<http://www.fotric.com/support-analyzir>**

# Appendix

## Emissivity Table

(For reference only)

Material Name	Surface Condition	Temperature (°C)	Emissivity ( $\epsilon$ )
Aluminum	Non-oxidized	100	0.20
	Oxidized	100	0.55
Brass	Polished brown	20	0.40
	Unpolished	38	0.22
	Oxidized	100	0.61
Copper	Severely oxidized	20	0.78
Iron	Oxidized	100	0.74
	Rusty	25	0.65
Cast iron	Oxidized	200	0.64
	Non-oxidized	100	0.21

Wrought iron	Roughened	25	0.94
	Polished	38	0.28
Nickel	Oxidized	200	0.37
Stainless steel	Oxidized	60	0.85
Steel	Oxidized at 800°C	200	0.79
Common brick	Surface	20	0.93
Concrete	Surface	20	0.92
Glass	Polished plate	20	0.94
Lacquer	White	100	0.92
	Natural color black	100	0.97
Carbon	Smoke black	25	0.95
	Candle soot	20	0.95
	Graphite rough surface	20	0.98
Paint	Average of 16 colors	100	0.94
Paper	White	20	0.93
Sand	Surface	20	0.90

Wood	Polished	20	0.90
Water	Distilled water	20	0.96
Skin	Human	32	0.98
Pottery	Fine	21	0.90
	Abrasive	21	0.93

**TRANSMETRA GmbH**

Messtechnik mit KnowHow.

**052 624 86 26**

**info@transmetra.ch**

**www.transmetra.ch**