

- Nenndrehmoment von 1 N·m ... 100 N·m
 - Beide Wellenenden mit Passfedern
 - Sehr kurze axiale Baulänge
 - Hohe Drehsteifigkeit
 - Zuverlässig und robust
 - Einfache Handhabung und Montage
 - Sonderausführungen auf Anfrage
- *Nominal torque from 1 N·m ... 100 N·m*
 - *Both shaft ends with keys*
 - *Very short axial length*
 - *High torsional stiffness*
 - *Reliable and durable*
 - *Simple handling and assembly*
 - *Special versions on request*



Technische Daten - Specifications

Artikel -Nr. Article-No	Nennmoment Nominal Torque [N·m]	Federkonstante Springrate [N·m/rad]	Massen- trägheits- moment Mass Moment of Inertia [kg·m ²]		Grenzlängskraft Limit Thrust Load [N]	Grenzquerkraft Limit Shear Force [N]
			Antriebsseite Drive Side	Messseite Test Side		
100384	1	2,78E+02	1,10E-05	3,78E-07	400	11
100383	2	2,78E+02	1,10E-05	3,78E-07	400	11
100382	5	8,03E+02	1,10E-05	3,86E-07	700	25
100381	10	3,22E+03	1,10E-05	4,07E-07	1150	51
100378	20	3,50E+03	1,11E-05	4,47E-07	1700	95
100377	50	1,17E+04	3,24E-05	2,44E-06	3700	190
100376	100	1,55E+04	3,26E-05	2,63E-06	4350	270

DK-15		
Genauigkeitsklasse - Accuracy class	% v. E - f. s.	0,2
Reproduzierbarkeit - Repeatability (DIN 1319)	%	±0,02
Speisespannung - Excitation voltage	VDC	2 ... 12
Brückenwiderstand - Bridge resistance	Ω	350
Nennkennwert - Nominal sensitivity	mV/V	1 ±0,2%
Referenztemperatur - Reference temperature	°C	23
Nenntemperaturbereich - Nominal temperature range	°C	-5 ... 45
Gebrauchstemperaturbereich - Service temperature range	°C	-15 ... 55
Temp. koef. des Nullsignals - Temp. coeff. of zero signal	% v. E./K - f. s./K	±0,02
Temp. koef. des Kennwerts - Temp. coeff. of sensitivity	% v. E./K - f. s./K	±0,01
Gebrauchsdrehmoment (statisch) - Service torque (static)	% v. E - f. s.	150
Grenzdrehmoment (statisch) - Limit torque (static)	% v. E - f. s.	200
Bruchdrehmoment (statisch) - Ultimate torque (static)	% v. E - f. s.	>300
Schwingbreite - Bandwidth (DIN 50100)	% v. E - f. s.	70 (Spitze - Spitze) - (peak - peak)
Schutzart - Level of protection (DIN EN 60529)		IP50
Elektrischer Anschluss - Electrical connection		3 m, freien Lötenden - 3 m, free soldered ends

Anschlussbelegung - Pin Connection

Grün - Green	Speisung (-) - Excitation (-)
Braun - Brown	Speisung (+) - Excitation (+)
Gelb - Yellow	Signal (+) - Signal (+)
Weiß - White	Signal (-) - Signal (-)
Grau - Grey	Kontrollsignal (Option) - Control signal (option)
Schirm - Shield	Schirm - Shield

Optionen - Options

Artikel- Nr. - Article-No.	Bezeichnung - Description		
100218	Kontrollsignal - Control signal	% v. E - f. s.	100
42828	Erweiterter Temperaturbereich - Extended temperature range		-30 °C ... 100 °C
42829	Erweiterter Temperaturbereich - Extended temperature range		-30 °C ... 120 °C



Option Kalibrierungen - Option Calibrations

Artikel-Nr. - Article-No.	Bezeichnung - Description	Stufen - Steps	Norm - Norm
400676	Linearitätsdiagramm - Linearity diagram	25%	Werksnorm - Factory standard
400664	Linearitätsdiagramm - Linearity diagram	10%	
400961	Werkskalibrierung - Proprietary calibration	3	VDI/DE 2646
400700	Werkskalibrierung - Proprietary calibration	5	
400688	Werkskalibrierung - Proprietary calibration	8	
	DAkKS-Kalibrierung - DAkKS-Calibration		auf Anfrage - on request

Mechanische Abmessungen - Dimensions

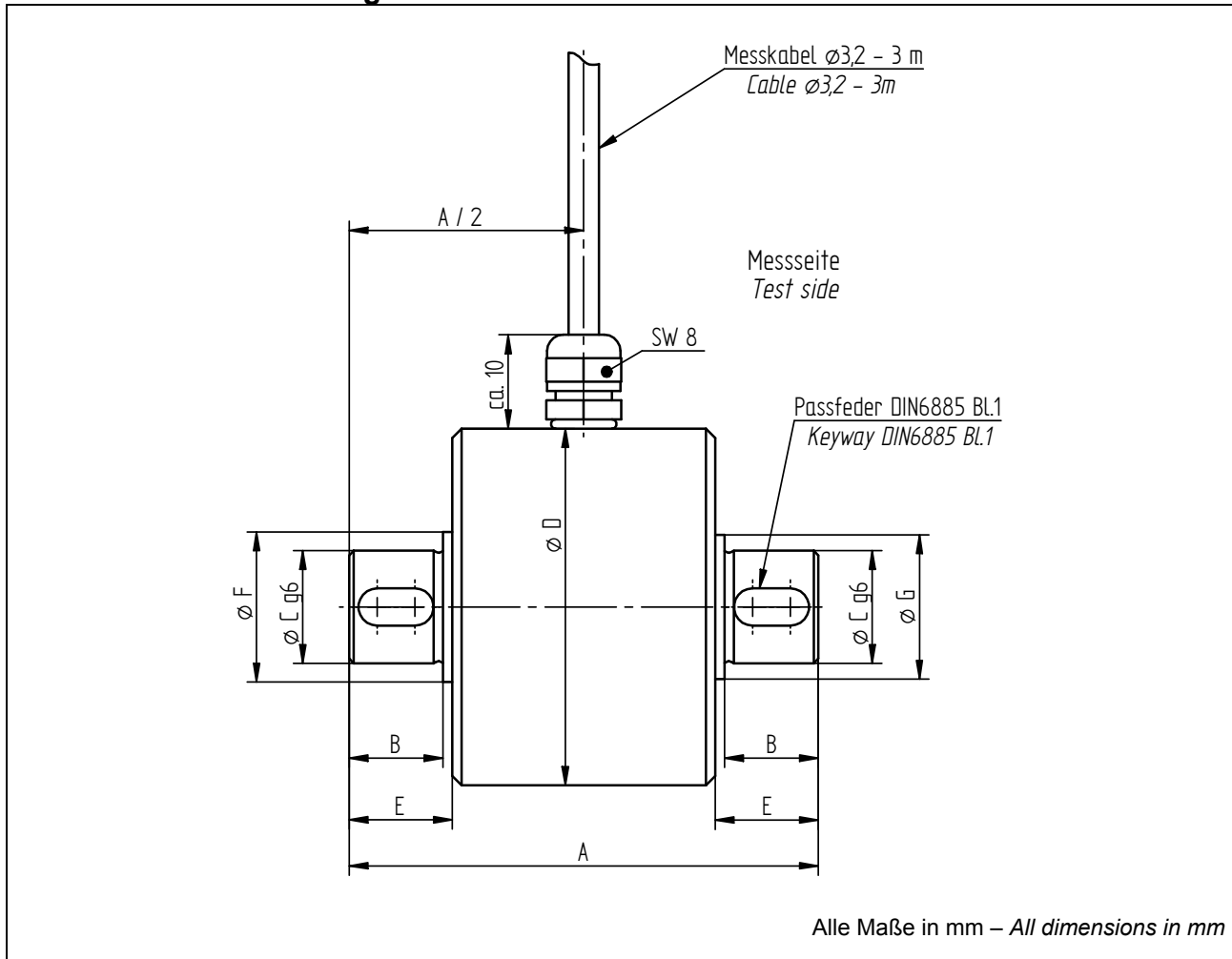

Nenn Drehmoment Nominal Torque [N·m]	Abmessungen - Dimensions [mm]						
	A	B	$\varnothing C$	$\varnothing D$	E	$\varnothing F$	$\varnothing G$
1 / 2 / 5 / 10 / 20	50	10	12	38	11	16	15,4
50 / 100	70	20	18	49	21,5	21	20,5