

# Fragen und Antworten zu Kraftsensoren

## FAQ Load Cell

### HOW DO I KNOW WHAT ACCURACY CLASS TO USE FOR MY SENSOR?

It depends on the application. How much does error in your project matter? If you're filling a tub with water then it may not matter at all. If you're filling of a tub with chemicals, the consequence of error could be severe.

If the consequences of error are significant, you should identify all sources of error and their contribution to total error. You can then „snap“ pressure sensors with different levels of accuracy into your evaluation and see the impact of sensor error on each.

If you have other error factors that are much larger than the transducer then upgrading the transducer accuracy may not matter.

Remember to translate the accuracy into hard numbers to get a better perspective. Is a 1000 PSI pressure transducer with .1 % accuracy good enough? The real question is whether an accuracy of +/- 1 PSI is accurate enough. Is detecting between 999 and 1001 PSI at a true pressure of 1000 PSI acceptable? It depends on the application. You can always opt for the highest accuracy, but it can be more beneficial to analyze accuracy in the context of the application's needs, transducer costs and transducer lead times.

### WHAT IS SENSITIVITY?

The ratio of change between a transducer's output and input is known as its sensitivity. For example, a transducer that produces 1 mV for every 100 psi has a sensitivity value of .01 mV/psi.

Under ideal conditions, a transducer's sensitivity value does not change between zero and full scale. A transducer that produces 1 mV for every 100 psi would then, under ideal conditions, also produce 2 mV for an applied pressure of 200 psi, 3 mV for an applied pressure of 300 psi, and so.

A transducer's ideal sensitivity can therefore be mapped as a straight line, and the transducer's sensitivity value, expressed as the ratio of output to input, then equates to the slope of that line

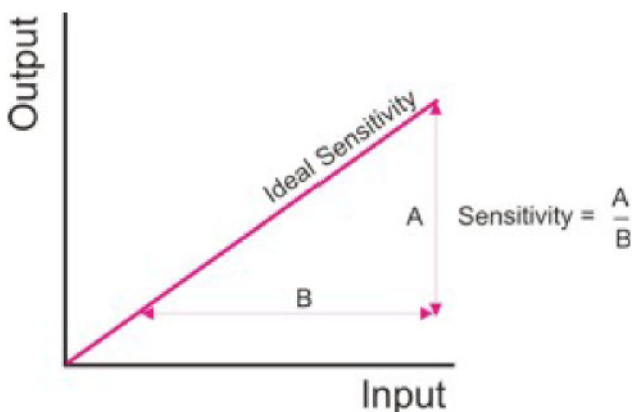

Ideal Sensitivity is Represented as a Straight Line

Notice also that under ideal conditions, there is zero output when there is zero input.

However, the actual sensitivity of a transducer fluctuates slightly between zero balance and full scale. Some reasons for this might be due to manufacturing and materials imperfections, electrical interference, and even the age of the transducer. In addition, a transducer usually produces some amount of output even at zero balance. Thus, true sensitivity actually equates to a non-linear function with a zero offset.



# Fragen und Antworten zu Kraftsensoren

## FAQ Load Cell

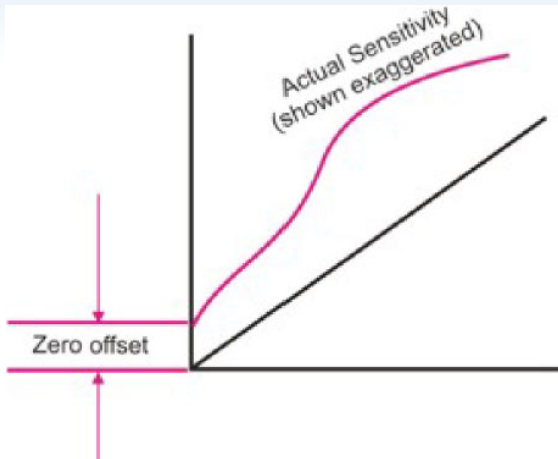

True Sensitivity is Represented as a Curve

However, the actual sensitivity of a transducer fluctuates slightly between zero balance and full scale. Some reasons for this might be due to manufacturing and materials imperfections, electrical interference, and even the age of the transducer. In addition, a transducer usually produces some amount of output even at zero balance. Thus, true sensitivity actually equates to

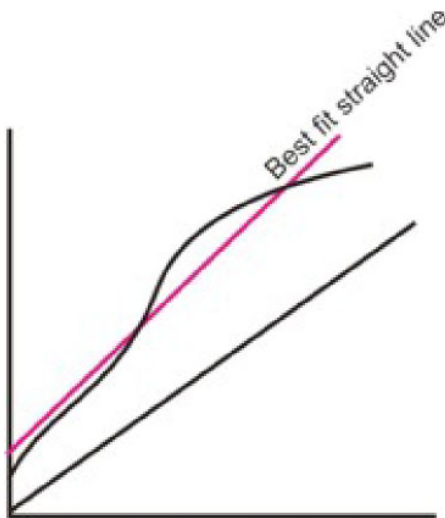

Because true sensitivity is non-linear, the true sensitivity value of a transducer (the ratio of output to input) will not always be the same at any point between zero balance and full scale. In order for a sensitivity value to be constant, the sensitivity must be expressed linearly. Most manufacturers use a best fit straight line to represent sensitivity.

Example of a Best Fit Straight Line

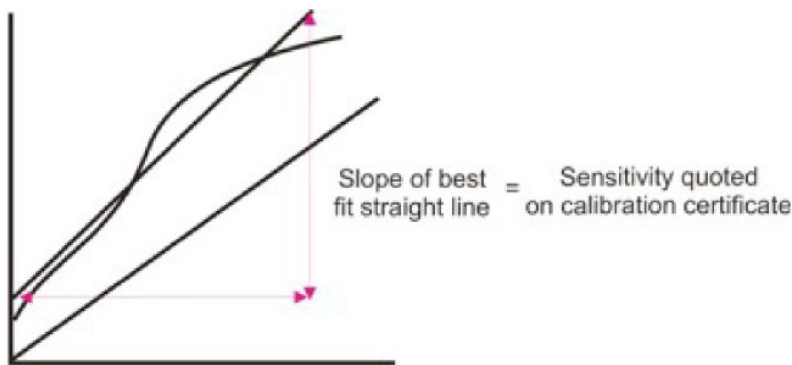

Sensitivity as the Slope of the Best Fit Straight Line

The sensitivity value can then be expressed as the slope of the best fit straight line, which becomes the value quoted on the transducer's calibration certificate.

In some cases, Sensotec uses the slope of a best fit straight line as a transducer's quoted sensitivity on its calibration certificate. In other cases, Sensotec uses the slope of a terminal point straight line. (See What is Non-Linearity?)

### WHAT IS NON-LINEARITY?

In its broadest sense, non-linearity refers simply to a departure from something that is linear. In the world of transducers, non-linearity is the maximum deviation in output between a transducer's sensitivity curve and a linear representation of its true sensitivity curve drawn between nominal zero and full scale. Non-linearity is measured on increasing input only, and is expressed as a percent of full scale output. An example of non-linearity for a transducer is  $\pm 0.15\%$  F.S.



# Fragen und Antworten zu Kraftsensoren

## FAQ Load Cell

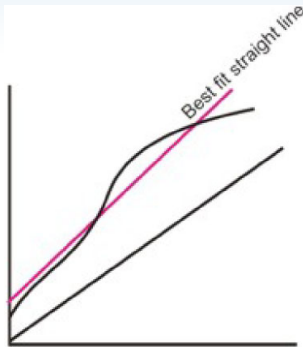

### Best Fit Straight Line Compared to Ideal Sensitivity

Determining non-linearity for a transducer raises a question of how to create the linear representation of a transducer's true sensitivity. Often a best fit straight line, which is based on the least squares method, is employed.

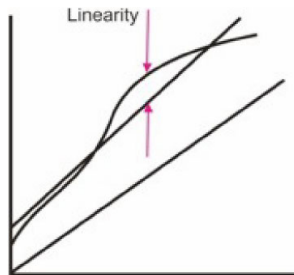

### Non-Linearity Based on Best Fit Straight Line

When a best fit straight line is used, transducer non-linearity is simply the greatest deviation between the transducer's sensitivity curve and the best fit straight line obtained mathematically using the least squares fit method

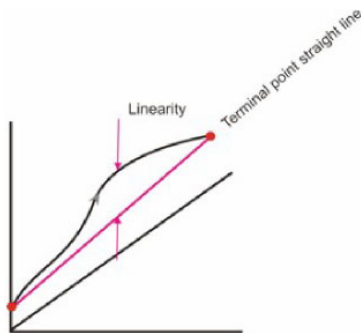

### Non-Linearity Based on Terminal Point Straight Line

In other cases, a terminal point straight line is used to determine transducer non-linearity. The terminal point straight line is drawn between nominal zero and output at full scale.

Terminal point straight line is often a more practical best straight line, as it is easy to understand and implement. The user simply takes the output at zero and the output at full scale and assumes a straight line relationship. Using a terminal point straight line results in a greater (worse) value for non-linearity than using a best fit straight line obtained mathematically.

Sensotec uses the terms linearity and non-linearity interchangeably. Sensotec uses the terminal point straight line method and least squares fit best straight line to determine its transducer's non-linearity. The datasheets indicate the method used when quoting specifications.

### WHAT IS HYSTERESIS?

Hysteresis refers to the behavior of a transducer to produce different output values for a common input point depending on whether applied input is increasing or decreasing.

Hysteresis is due to the behavioral patterns of metal crystals, which expand and contract differently. As applied pressure on a transducer increases, the non-linear representation of the transducer's output traces its true sensitivity curve. But as applied pressure on a transducer decreases, the non-linear representation of transducer output results in a different sensitivity curve.

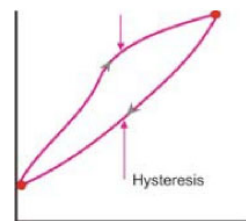

### WHAT IS STATIC ERROR BAND?

Static error band is a performance specification that takes into account the effects of transducer non-linearity and hysteresis.

The static error band is an error envelope that is determined by drawing two lines parallel to the best fit straight line (going through normalized zero point) with a width that is determined by the hysteresis curve. An example of static error band for a transducer is  $\pm 0.04\%$  F.S.

Notice that a best fit straight line, rather than a terminal point straight line, is used to calculate transducer error band. The best fit straight line must take into account both curves. Once the best fit straight line has been determined, two lines, which are both parallel to the best fit straight line, are then drawn through the points of maximum deviation. The entire region between these outer lines is known as the static error band.



# Fragen und Antworten zu Kraftsensoren

## FAQ Load Cell

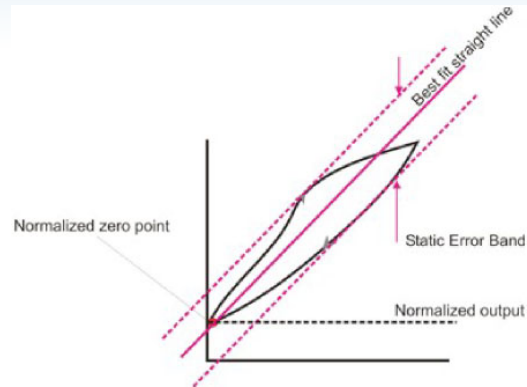

Static Error Band and the Best Fit Straight Line

### WHAT IS CALIBRATION FACTOR?

Calibration is the process of standardizing an instrument by determining its deviation from a desired standard. It is through the calibration process that one obtains the proper correction factors for the transducer's deviation. Calibration is essentially the comparison of transducer outputs when compared to a reference standard. Every transducer is shipped with a sensitivity on its calibration certificate so that the electronic equipment associated with the transducer can be set up correctly. Sensotec expresses the sensitivity of the transducer by stating a calibration factor rather than a sensitivity.

The calibration factor for a transducer is the transducer's output value at full scale when the output has been normalized (i.e. zeroed). The line drawn through normalized zero and a transducer's calibration factor equates to the best fit straight line of the transducer output. Thus, the transducer's calibration factor in effect establishes the transducer's sensitivity.

### Calibration Factor Quoted on the Calibration Certificate

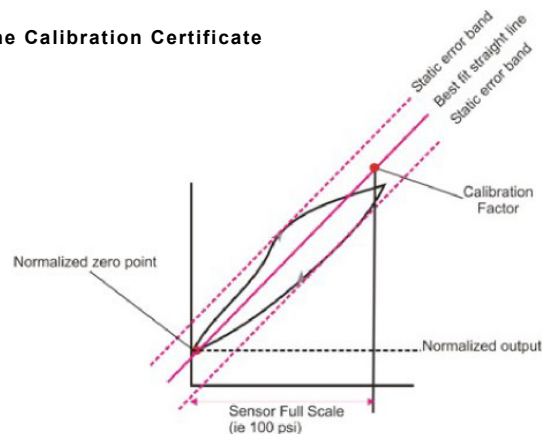

### WHEN SHOULD I FIT A CONNECTOR OR INTEGRAL CABLE?

Using a connector makes it easy to disconnect (or reconnect) a sensor's cabling which also makes it easier to remove or replace the sensor too. Thus, using connectors is an excellent choice for temporary sensor applications. However, in addition to sometimes being more expensive than integral cable options, connectors introduce a point of vulnerability for potential water, moisture, and mechanical damage in the connection itself.



Because of size constraints, it is often impractical or impossible to fit connectors to small sensors; thus, integral cable technology is often the only option for small sensors. As can be imagined, integral cables are often used for more permanent installations, where connecting and disconnecting a sensor's cabling is not planned. Because the cable is integrated with the sensor, the points of vulnerability with respect to water, moisture, and mechanical damage that can occur with connector technology, are eliminated; on the other hand, integral cables require strain relief protection to prevent the cable from getting sheared off or ripped out. If an integral cable is ever damaged, the entire sensor must be repaired or replaced.





# Fragen und Antworten zu Kraftsensoren

## FAQ Load Cell

While it is possible to fit a connector to a submersible sensor (using a submersible connector), using an integrated cable is much more cost effective. Because a submersible sensor (Fig 24c) is typically part of a permanent installation, an integrated cable becomes a much more practical choice. In some cases, though, an application might not require true submersibility, but only a degree of water protection; thus one must be able to identify the true need.



The following table summarizes the advantages and concerns for connectors and integral cables:

 Connector	 Integral Cable	 Submersible
Easy to disconnect cabling from the sensor  Easy to replace the sensor  Ideal for temporary installations  More expensive Point of vulnerability  Subject to water, moisture, mechanical damage	Ideal for permanent installations  Often the only option on small sensors  Cable must be protected to avoid damage  Strain relief often required  Cable damage means replacing or repairing sensor	Submersible connectors are very expensive  Integral cable is a more cost effective solution  More permanent installation (by definition)  Ensure of definition between waterproof and submersible

### WHAT IS THE DIFFERENCE BETWEEN SUBMERSIBLE AND WATERPROOF?

There are many categories of environmental protection against water. For example, a product might be designed for water protection in various forms, such as protection from dripping; spraying; splashing; jet spray; immersion; submersion; and so on. A product with an environmental protection rating against dripping water might not have sufficient protection against splashing water or jet spray. Similarly, a product protected against spraying or splashing might not have sufficient protection against submersion.

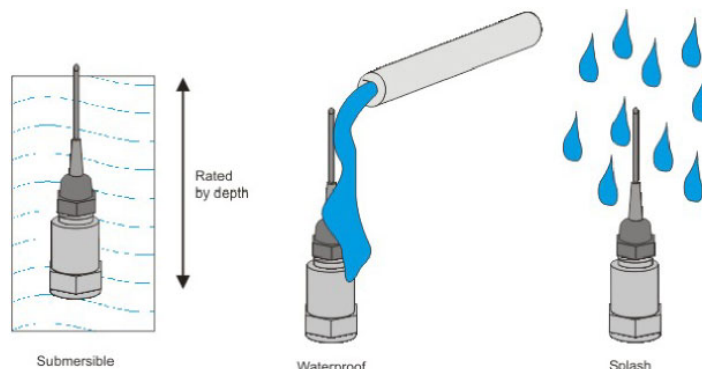

Waterproof is a general term with respect to environmental protection. A waterproof sensor might actually be rated only against a specific type of water ingress, such as splashing, dripping, spraying, and so on. A sensor that is rated against submersion, on the other hand, is probably also protected against all other forms of water ingress.

Submersible sensors, which are rated by depth of submersion, enjoy the highest environmental protection against water.



# Fragen und Antworten zu Kraftsensoren

## FAQ Load Cell

### WHAT ARE NEMA AND IP DEFINITIONS FOR ENVIRONMENTAL PROTECTION?

The National Electrical Manufacturers Association (NEMA) has been developing standards for the electrical manufacturing industry for more than 70 years. NEMA's environmental protection standards, which are used in America, are expressed numerically as follows:

Number	Meaning
1	General Purpose (Indoor)
2	Water Drip Proof (Indoor)
3 R	Dust Tight, Rain Tight, and Ice Resistant (Outdoor)
4	Water Tight and Dust Tight (Indoor/Outdoor)
4 X	Water Tight, Dust Tight, and Corrosion Resistant (Indoor/Outdoor)
9	Indoor Hazardous Locations (Not Applicable to EMS Equipment)
12	Industrial Use - Dust Tight and Drip Tight (Indoor)
13	Oil Tight and Dust Tight (Indoor)

Thus, an enclosure that is rated as NEMA-4 is both water tight and dust tight, whether indoors and outdoors.

Europe uses a different system (IP) to express environmental protection for enclosures. Protection categories are expressed by two numbers. Each number defines the protection level. The first number refers to a particles protection; the second number refers to water protection.

IP No		Definitions: IP##	
1st #	Meaning	2nd #	Meaning
0	No Special Protection	0	No Special Protection
1	Protected Against Solid Objects > 50mm in Diameter	1	Protected Against Dripping Water
2	Protected Against Solid Objects <12mm in Diameter	2	Protected Against Dripping Water When Tilted Up to 15D C From Normal Position
3	Protected Against Solid Objects <2.5mm in Diameter	3	Protected Against Spraying Water
4	Protected Against Solid Objects <1mm in Diameter	4	Protected Against Splashing Water
5	Dust Protected	5	Protected Against Water Jet Spray
6	Dust Tight	6	Protected Against Heavy Jet Spray
		7	Protected Against the Effects of Immersion
		8	Protected Against Submersion

For example, IP54 is considered both dust protected and splash protected.

Note that there is a difference between the effects of immersion and submersion. Immersion protection means that an ingress of water will not cause harmful effects when the enclosure is temporarily immersed in one meter of water for standard conditions of pressure and time. Submersion, on the other hand, means that an ingress of water will not cause harmful effects when the enclosure is continuously immersed in water under more severe conditions, which are agreed upon by the manufacturer and user.





# Fragen und Antworten zu Kraftsensoren

## FAQ Load Cell

### WHAT IS OVERLOAD PROTECTION ON A LOAD CELL?

Overload protection in a general sense refers to how a system or device is protected from damage that can result from an input that exceeds a designed limit. For example, overload protection in an electrical application might involve using a fuse or circuit breaker to protect the system from a current overload.

Overload protection on a load cell refers specifically to the means used to prevent the cell's diaphragm from deflecting beyond its designed elastic limit. Without overload protection, a load cell's diaphragm experiences irreversible damage under too much applied input.

To achieve overload protection in a load cell, a mechanical stop is inserted to prevent the diaphragm from deflecting beyond its elastic limit. The mechanical stop bottoms out when excessive load is applied.

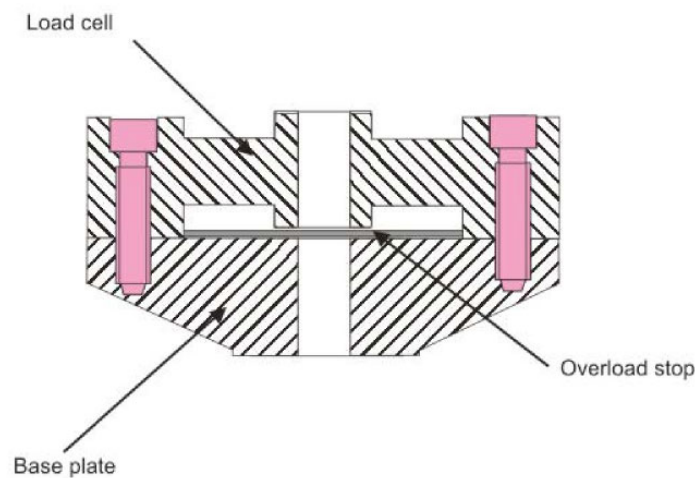

Overload Protection on a load cell (in this case mounted between base plate and load cell)

Load cells that do not have mechanical overload protection enjoy an overload capacity by default typically 50%. This means that a 100 lbf load cell without mechanical overload protection can sustain a 150 lbf load without incurring damage.

Notice that when a load cell's maximum designed input limit is exceeded, the load cell's output does not increase further (the output becomes asymptotic)

Mechanical overload protection lends itself more easily to compression load cells than to tension load cells. Because of the internal mechanical design of tension load cells, it is difficult to insert a mechanical stop that provides sufficient overload protection.

Because of the typical design of most load cells, Sensotec can fit overload stops on most compression load cells, but on only a few tension load cells. There are also some load cells that, because of their unique shape, are unable to have overload stops in either compression or tension.

Every load cell has a slightly different deflection. Because tolerances on a load cell's internal dimensions are not tight enough to permit a generic overload protection stop, any protection stop that is inserted must be custom made, custom fitted, and then custom tested. This process increases the cost significantly.



# Fragen und Antworten zu Kraftsensoren

## FAQ Load Cell

### WHAT IS A COMPRESSION ONLY LOAD CELL?

A compression only load cell is a load cell that has been designed specifically to measure only compression.

Most load cells work in both compression and tension to some degree. However, some load cells, by virtue of their physical construction, are better suited to either compression or tension.

Sometimes it is preferable to use a load cell that measures both compression and tension without enabling its tension measuring capability. Rather than design a load cell that measures only compression, a load cell capable of measuring compression and tension can be shipped with calibration simply carried out only for compression. This type of load cell might be considered a compression-only load cell, although it is technically a compression and tension load cell being used only for compression.

Compression-only load cells are usually fitted with a load button to minimize side loading.

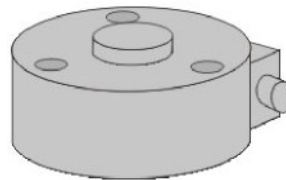
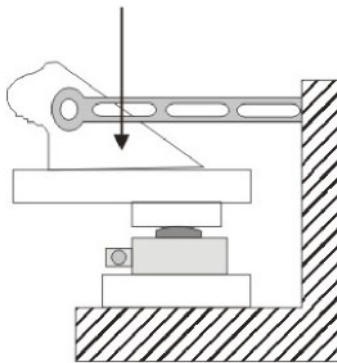

Compression only application

The physical design of the load cell is typically better suited for either compression or tension. Compression-only load cells tend to have a high diameter to height ratio. Tension-only load cells, on the other hand, tend to have a high height to diameter ratio.

When a compression and tension load cell is used only for compression, calibration is provided only for compression loading. It is more expensive to provide calibration in both directions for a load cell. It is less expensive, on the other hand, to provide calibration in just one direction (tension only or compression only).

It is also important to consider which physical attachments will come into play with a load cell's application. Some load cells will be better suited for specific attachments.

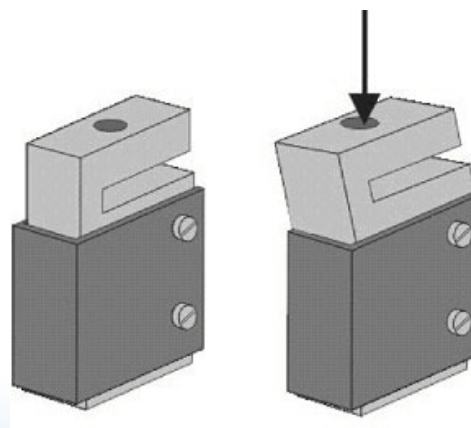

Some Load Cells are not designed for compression load

Physical design of a tension load cell





# Fragen und Antworten zu Kraftsensoren

## FAQ Load Cell

Sometimes it is preferable to use a load cell that measures both compression and tension without enabling its compression measuring capability. Rather than design a load cell that measures only tension, a load cell capable of measuring compression and tension can be shipped with calibration simply carried out only for tension. This type of load cell might be considered a tension-only load cell, although it is technically a compression and tension load cell being used only for tension.

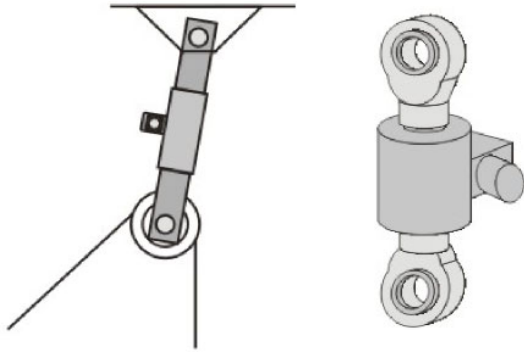

Tension Only Application and load cell fitted with rod end bearings. Tension-only load cells tend to be long in shape, and are often fitted with rod end bearings, which minimize side loading.

### WHAT IS A TENSION AND COMPRESSION ONLY LOAD CELL?

A tension and compression load cell is a load cell that has been designed specifically to measure both tension and compression. Most load cells work in both compression and tension to some degree. However, some load cells, by virtue of their physical construction, are better suited to either compression or tension. Thus, a tension and compression load cell is one that has been physically designed in such a way to be able to measure both compression and tension effectively.

Note that a tension and compression load cell should come with two calibration factors: one for compression measurement, and one for tension measurement.

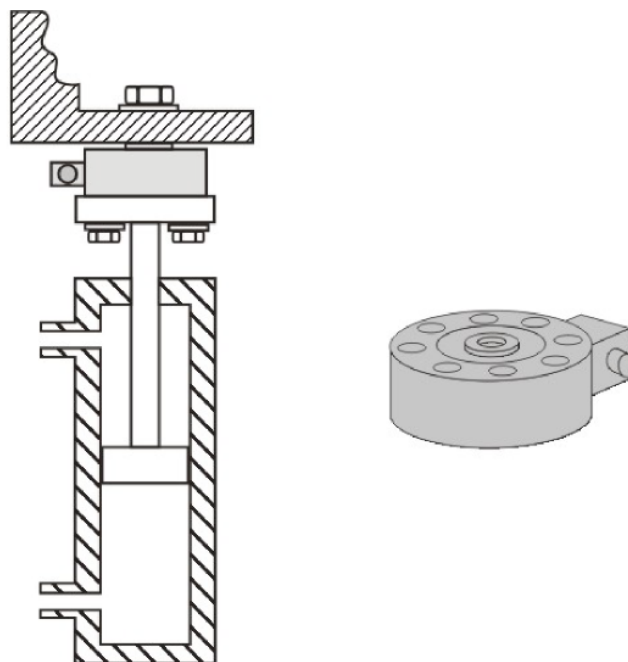

Tension & compression application

Note: Load cells are supplied with tension-only calibration unless the tension/compression calibration option is ordered.



# Fragen und Antworten zu Kraftsensoren

## FAQ Load Cell

### WHAT IS A ROD END BEARING?

Rod end bearings are self-aligning spherical bearings used in tension applications to prevent side loading. Using male or female attachments, rod end bearings attach to a static rod. The bearing itself swivels in order to accommodate the rod's varying misalignment. Ratings exist for both load capacity and lubrication requirements. Some rod end bearings can actually be created with integrated threaded studs in the bearing. Common applications for rod end bearings include linkages, shift control rods, and use with tension load cells.



Male Rod End Bearing



Female Rod End Bearing

### WHAT IS A LOAD BUTTON?

A load button is a physical feature of a compression load cell. A load button is a domed shaped loading point that is welded or threaded onto the side of the load cell that has been designated to receive the applied load. Load buttons are used to measure compression loading correctly by eliminating the potential for side loading. A load button is rounded so that the load being measured always rests on the highest point of the button. A load button ensures that the entire applied load issues a force in a direction that is perpendicular to the load cell.

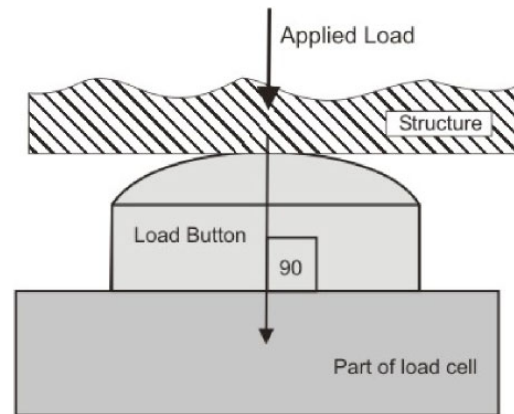

Load Button Ensures a Force Perpendicular to the Load Cell

### WHAT IS LOAD CELL SYMMETRY?

Load cell symmetry refers to whether a load cell exhibits the same sensitivity for both compression and tension usage.

All load cells have a non-symmetry of a greater or lesser extent. The linear representation for compression in a load cell is not, by default, symmetrical to the linear representation for tension. Thus, when both sensitivities are mapped, the sensitivity curves for compression and tension are different and have a different slope.

Most tension and compression load cells are used in only one direction for an application so the question of symmetry is not an issue. On some occasions, though, applications might call for true symmetry in a load cell. An example might be an application, which measures both compression and tension in a hydraulic line. In this case, working with a single calibration factor for both directions might be preferred to having to balance two calibration factors. This convenience can be achieved if the load cell exhibits near true symmetry.

It is possible to achieve near true symmetry in a load cell. The process, however, is expensive.



# Fragen und Antworten zu Kraftsensoren

## FAQ Load Cell

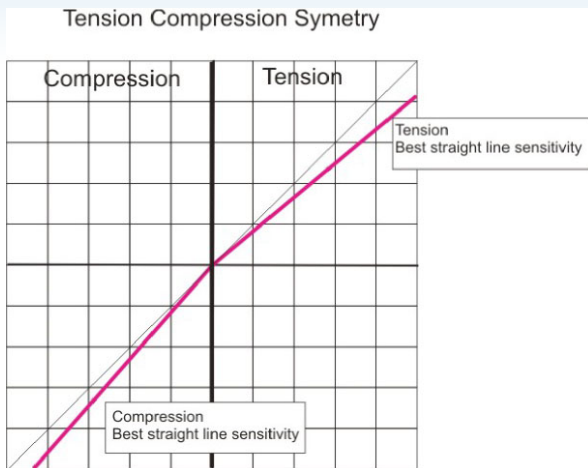

**Note:**  
Symmetry can be calculated and minimized for customers where this phenomenon is an issue. Calibration class load cells have very low symmetry characteristics.

### WHAT IS ZERO BALANCE FOR A LOAD CELL?

Zero Balance is the load cell output when no load and proper supply voltage are applied. Zero balance is expressed as a percentage of full scale. Ideally, the output would be exactly zero, but it is not due to several factors.

The electrical and mechanical components of transducers have inherent stresses and offsets during the assembly process. These offset the zero balance.

Bridge unbalanced during manufacture

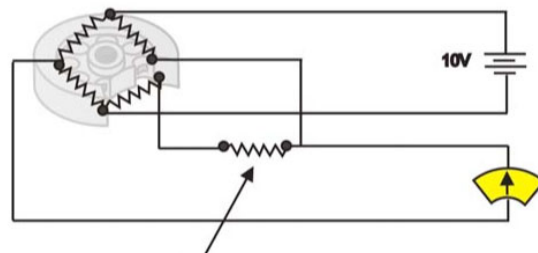
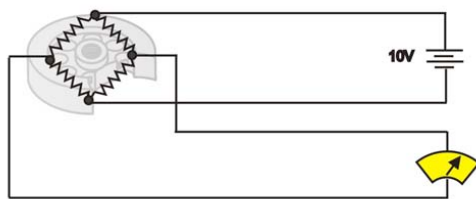

Zero balance resistor added to bridge network.  
We add resistance to ensure satisfactory zero balance for new transducers.

Zero offset present during manufacture

Operating environment and transducer history can change the zero balance. Factors include temperature, transducer age, and transducer overload. If customers notice a change in their zero balance, they may want to adjust their balance using either external instrumentation or local zero adjustments. Annual testing and certification can ensure precise output throughout the life of the transducer.

### WHAT IS ZERO BALANCE TEMPERATURE EFFECT?

Zero balance is the load cell output at no load. This balance changes as temperature changes

Individual gages do not behave exactly the same with temperature

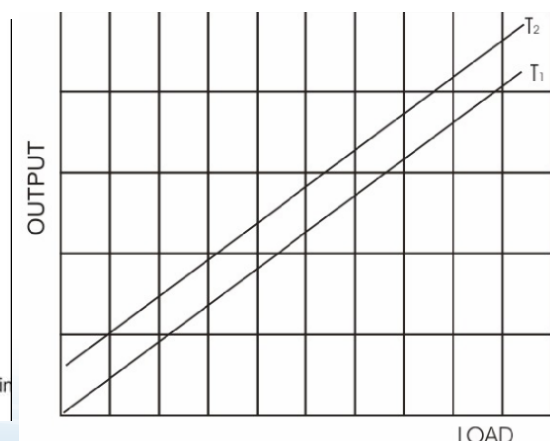
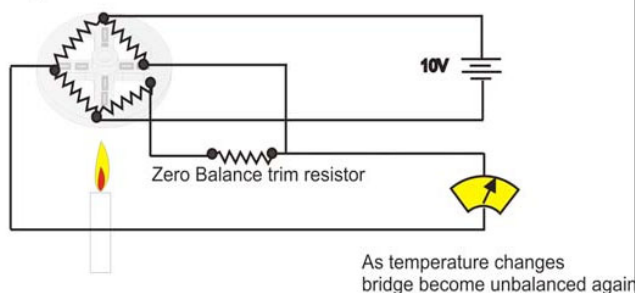

# Fragen und Antworten zu Kraftsensoren

## FAQ Load Cell

We can minimize the zero balance change due to temperature by inserting compensating resistors. When a temperature changes drive the transducer output higher, the changes are also driving the compensation resistor to lower output. The zero balance offset is described as a percentage of full scale change per degree Fahrenheit (% F.S. / F) A 10000 lb sensor with .002% F.S. / F will have a zero shift of 0.2 lbs for every degree change from the calibration reference temperature.

### WHAT IS OUTPUT SPAN TEMPERATURE EFFECT?

Output Span refers to the output between zero and full scale. The output span is the output value of the sensor at full load (Calibration factor), expressed as mV/V. A sensor with a calibration factor of 3 mV/V will have an output of 30 mV at full load if it is being supplied with 10V power.

Output span varies with temperature, and we insert span compensating resistors to minimize this variation.

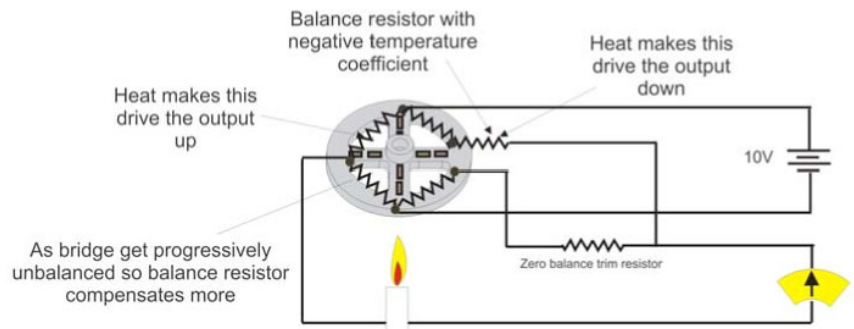
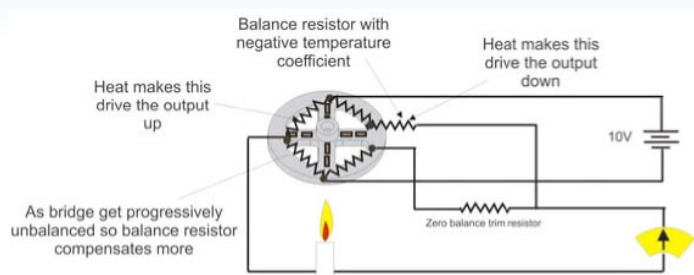

Given output for a given load at reference temperature

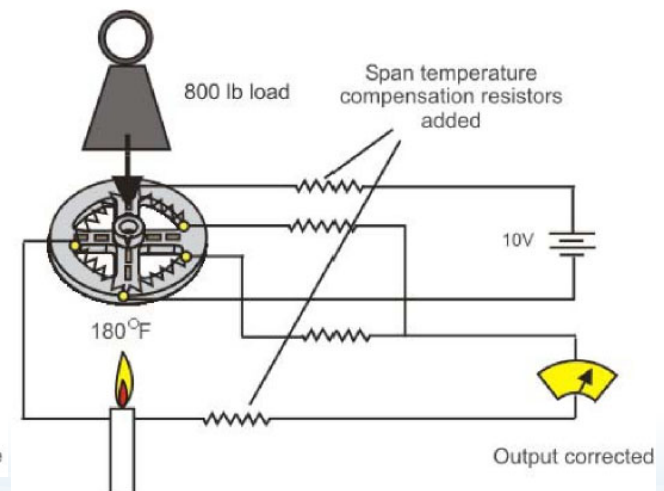
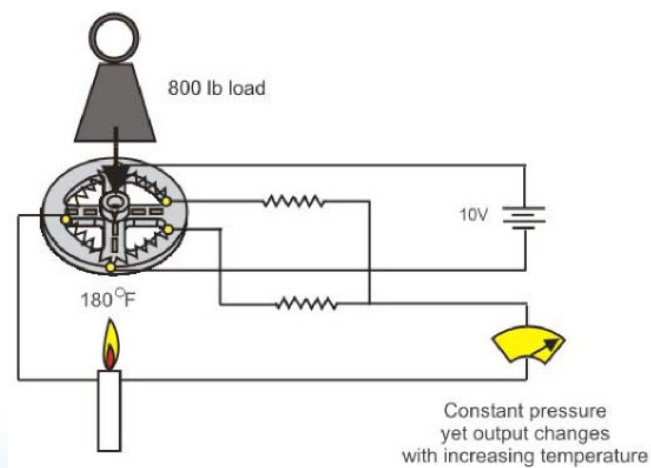
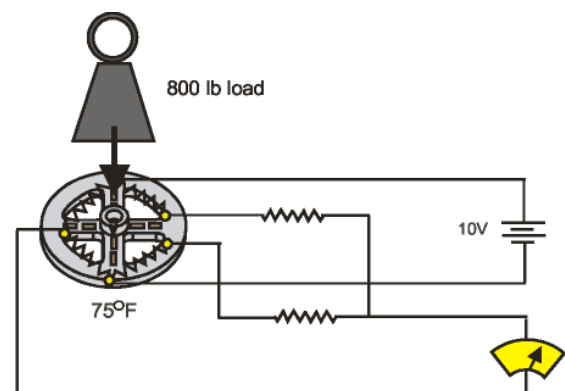
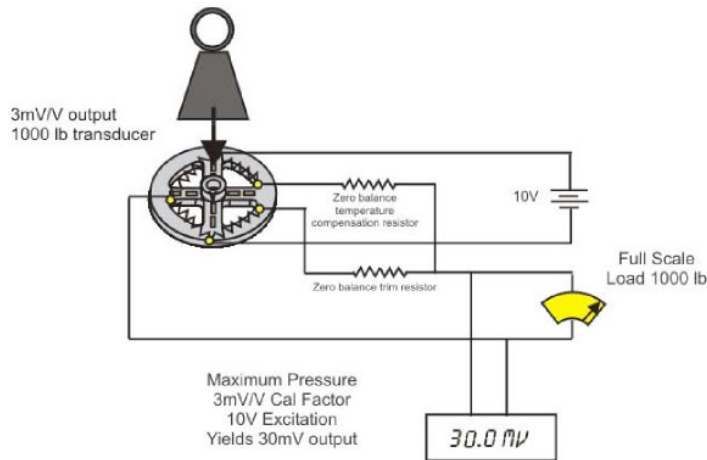

# Fragen und Antworten zu Kraftsensoren

## FAQ Load Cell

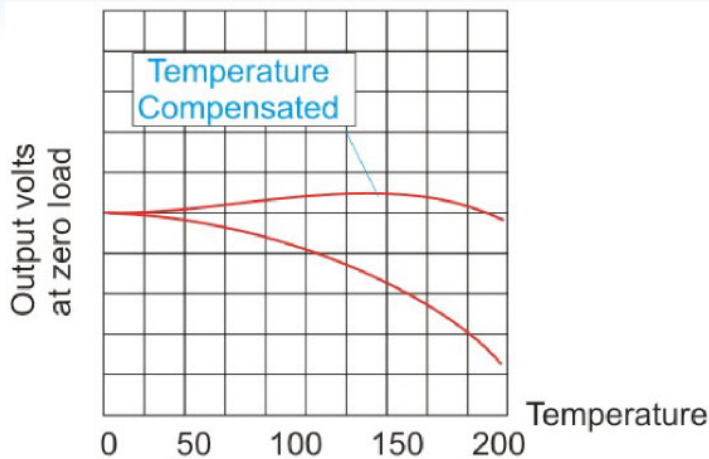

The temperature effect on span is measured as a percentage change in rated output per degree of temperature change. A 10000 lb load cell with .002 Rdg/F will exhibit 0.2 lb span shift for each degree of temperature change.

Customers can adjust the zero and span of their outputs by adjusting the zero and span adjustments on their transducer (If they have internal amplification), or on the instrumentation that reads the transducers.

### WHEN SHOULD I HAVE ZERO AND SPAN ADJUSTMENTS ON MY LOAD CELL?

Zero and span may shift due to temperature, repeated loading, or sensor aging. The preferred method to adjust zero and span is through the use of external instrumentation. This allows users to track the changes they've made and revert back to previous values if needed.

Customers may purchase amplified output load cells with zero/span adjustments directly on the unit. This also allows for zero and span adjustment, but does not allow the user to track changes or revert to previous values. Once adjusted, the sensor is no longer calibrated as it was from the factory. Customers will also want to consider the operating environment of the transducer when selecting whether or not to use sensors with zero/span adjustments. If the sensor were going to be inaccessible, then it would be better to not have adjustments directly on the sensor.

A significant advantage of having the adjustment screws is that users can get calibrated, precise output by use of annual testing and certification, even as the transducer wears or ages in service.

### WHAT ARE THE ADVANTAGES AND DISADVANTAGES OF HAVING A SENSOR INTERNAL AMPLIFIER ON A LOAD CELL?

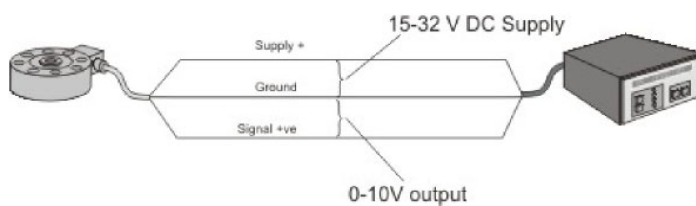

Systems without internal amplification must receive supply voltage from an external source, and must send small signals (i.e. 30mV) back to the amplifying source.

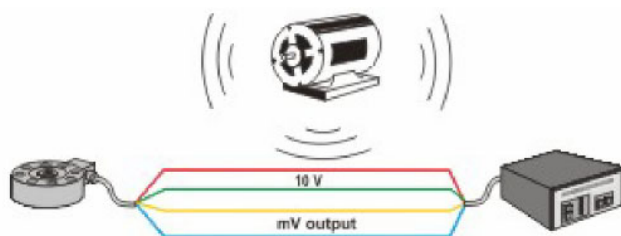

A good sensor output may become distorted by the electrical noise. These errors can be large and give signal to noise ratios of less than 20.

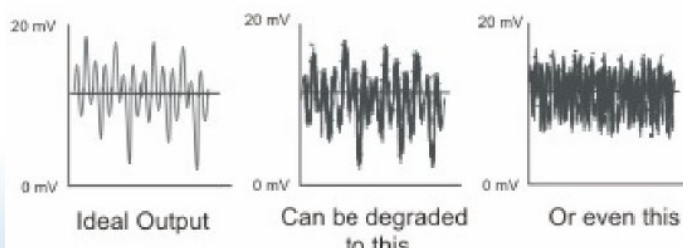



# Fragen und Antworten zu Kraftsensoren

## FAQ Load Cell

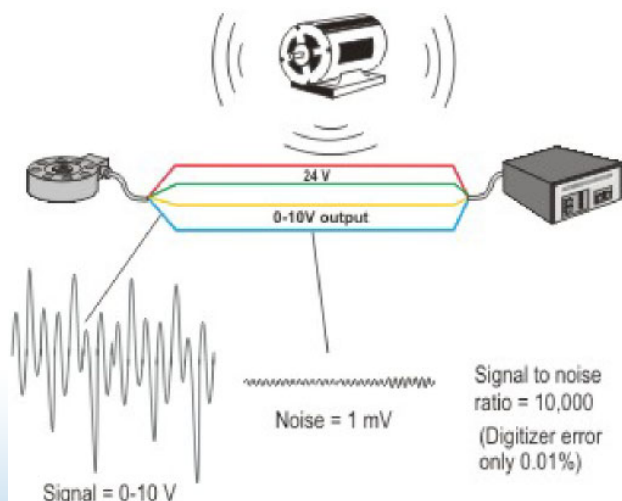
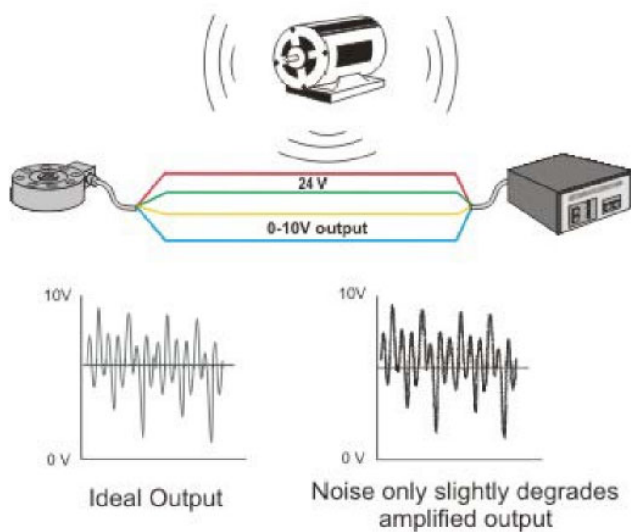
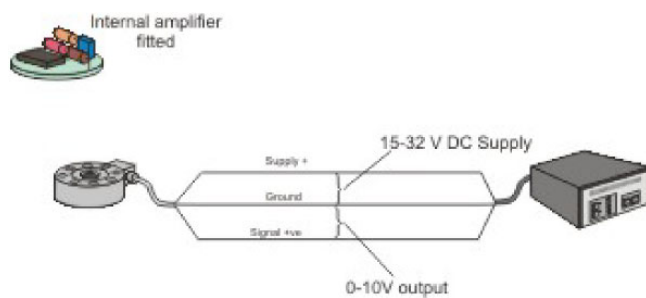
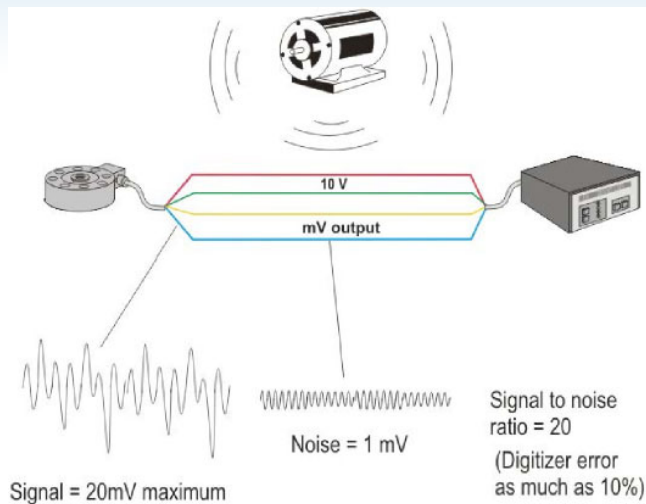

Internal amplification is a good way of reducing the effects of noise. The internal amplifiers are housed in the same unit as the sensor. This ensures the signal amplification is accomplished inside the transducer.

This makes the system less vulnerable to electrical noise and creates a higher signal to noise ratio. The larger output also allows A/D converters to create a higher resolution output. Because the internal amplifiers are so close to the sensor, line drops in excitation are eliminated.

The amplifier outputs are low impedance, and internal amplifiers, although they have some ripple associated with them don't contribute noticeably to system inaccuracy and signal to noise ratios of 10,000 are not uncommon.

Internal amplifiers may not be feasible under certain conditions. Specifically, the circuitry in the amp cannot be subjected to extreme temperatures. If sensor placed in a location inaccessible to users (hazardous environment, small space, long distance), zero and span adjustments may not be able to be tweaked when needed. Internal amplifiers increase the overall size of the unit, which may be concern in some applications.





# Fragen und Antworten zu Kraftsensoren

## FAQ Load Cell

### WHY IS THE OUTPUT OF MY PRESSURE DETECTOR QUOTED IN MV/V ?

mV/V output allows you to eliminate much of the error due to power supply voltage change.

A mV/V output implies that different levels of excitation may be provided to the transducer. The full-scale output of the transducer varies directly with the excitation. A sensor with a calibration factor of 3 mV/V will exhibit 30 mV at full pressure if it is being supplied with 10V power, but only 15 mV at full pressure if it is being supplied with 5 V.

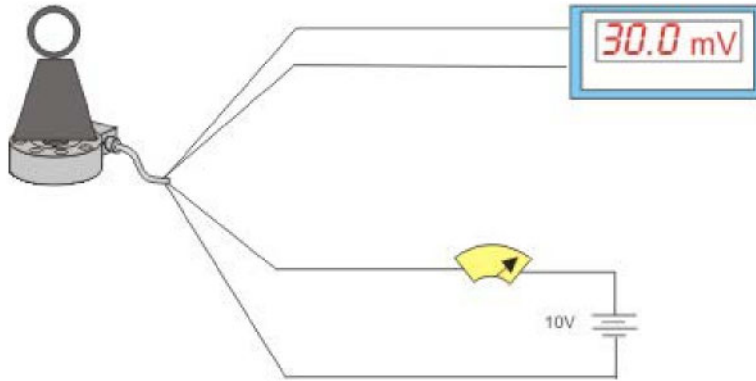

Output varies with supply voltage. If we don't know how much the change in supply voltage affected our output, then we cannot possibly know how much our change in output was due to an actual change in pressure

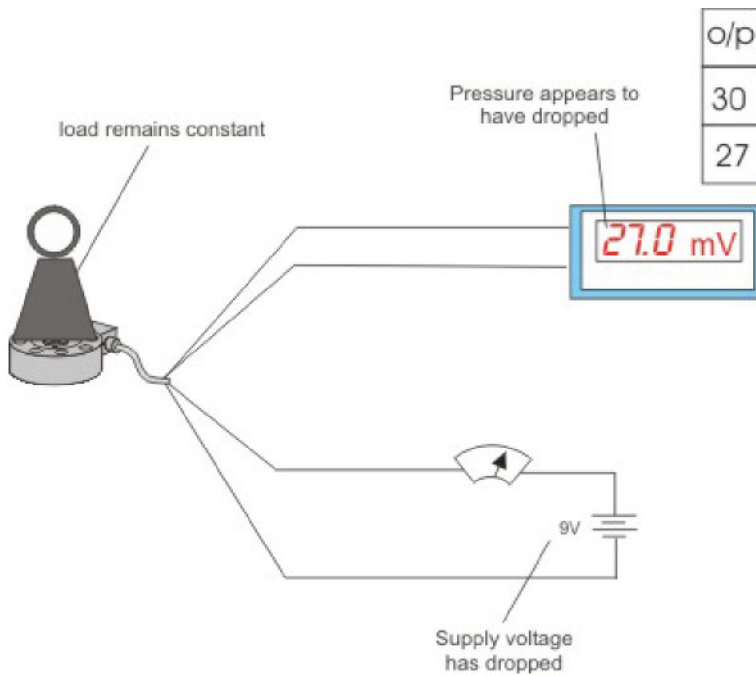

Many users monitor transducer output AND power supply excitation. Changes in output are compared to the supply voltage to discount effects from voltage shifts. Using the mV/V relationship, users can tell how much of their output change was due to an actual change in pressure.

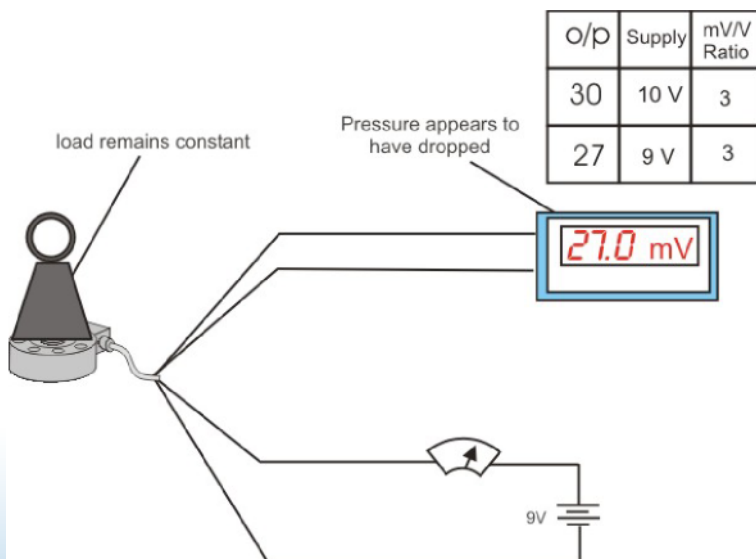

O/p	Supply	mV/V Ratio
30	10 V	3
27	9 V	3

This approach is known as a ratio metric approach because it relies on the ratio of voltage output to the Calibration Factor (mV/V) to determine pressure.

e. g. if we have a 3 mV/V, 100 lb load cell:

Supply Voltage	Load	Output
10 V	100 lbs	30 mV
5 V	100 lbs	15 mV



# Fragen und Antworten zu Kraftsensoren

## FAQ Load Cell

---

### HOW DO I KNOW WHAT ACCURACY CLASS TO USE FOR MY SENSOR?

It depends on the application. How much does error in your project matter? If you're filling a tub with water then it may not matter at all. If you're filling of a tub with chemicals, the consequence of error could be severe.

If the consequences of error are significant, you should identify all sources of error and their contribution to total error. You can then „snap“ load cells with different levels of accuracy into your evaluation and see the impact of sensor error on each.

If you have other error factors that are much larger than the transducer then upgrading the transducer accuracy may not matter. Remember to translate the accuracy into hard numbers to get a better perspective. Is a 1000 lb load cell with 0.1% accuracy good enough? The real question is whether an accuracy of +/- 1 lb is accurate enough. Is detecting between 999 & 1001 lbs at a true load of 1000 lbs acceptable? It depends on the application.

You can always opt for the highest accuracy, but it can be more beneficial to analyze accuracy in the context of the application's needs, transducer costs and transducer lead times.

### HOW DOES TEMPERATURE AFFECT A LOAD CELL?

Temperature causes changes in zero and span shift for load cells.

### HOW DO YOU COMPENSATE FOR TEMPERATURE IN A LOAD CELL?

The characteristics of all transducers vary with temperature. We install additional components that act opposite of the transducer's inherent temperature characteristics. If the transducer's components increase output with temperature, the compensation components decrease output, and viceversa.

To select the proper compensation components, we conduct a thorough test. We vary the pressure and temperature while measuring the output. We use this data to select components that best compensate for temperature in each specific load cell.

### WHAT IS THE TEMPERATURE COMPENSATION RANGE?

The temperature compensation range is the temperature range in which our sensor can be operated up to full scale while still maintaining our accuracy specifications. This is different than the temperature operating range, which is the temperature range in which the sensor may be operated safely but the accuracy specifications may not be met.

### WHAT IS THE TEMPERATURE OPERATING RANGE?

The temperature operating range is different than the temperature compensation range, and it is critical to understand the difference between the two. The temperature operation range is the range of temperatures in which our sensor can be safely operated up to full scale (accuracy specifications MAY NOT be met). The temperature compensation range is the range in which sensor can be operated up to full scale while still meeting our accuracy specifications.

### HOW DO I PICK THE RIGHT FULL SCALE OUTPUT FOR A LOAD CELL?

Several factors should be considered when selecting the right full scale output for a load cell.

What is the maximum transient load your system will see? Transients may degrade sensor performance if they are too extreme. To evaluate if your transient is acceptable, compare it to the safe overload rating. The safe overload rating of the transducer is the maximum load that can be applied without permanently degrading the sensor's characteristics.



# Fragen und Antworten zu Kraftsensoren

## FAQ Load Cell

How often will the load in your system cycle? Transducers, like all mechanical components, wear over the course of many cycles. This wear can change your transducer characteristics. One way to extend your transducer's life over many

cycles is to pick a larger range load cell.



Load ranges for a typical load cell

Dynamic loading can be a very significant factor when considering the load range to choose for your application. See Dynamic loading of load cells.

### WHAT IS THE EFFECT OF DYNAMIC LOADS ON A LOAD CELL?

Dynamic loads on a load cell can have a dramatic effect on your load cell and in many cases destroy your load cell without you being aware of it. Dynamic loads are fast acting loads that require high frequency signal conditioning to detect it because often they happen so fast. If the system is designed correctly unknown dynamic loads are not a problem. Dynamic loads often occur during installation when the cell is at its most vulnerable. Consider a 100lb load cell sitting on the floor. If a 3/8inch ball bearing weighing less than 2 oz's is dropped from a height of 18 inches the load cell experiences a 161 lb load. This innocuous effect permanently damages the load cell. Any signal conditioning attached to the load cell would have to have an update rate of 300 updates per second to detect this high-speed event. Thus a dropped wrench on the load cell or the dropping of the load cell on the floor from just a few inches can damage the cell. Damage is dramatically reduced when the forces applied on the load cell are not generated by hard incompressible surfaces. If the floor is wood or hammer blow was inflicted by a brass head instead of steel, then forces generated and damage done is considerably less.

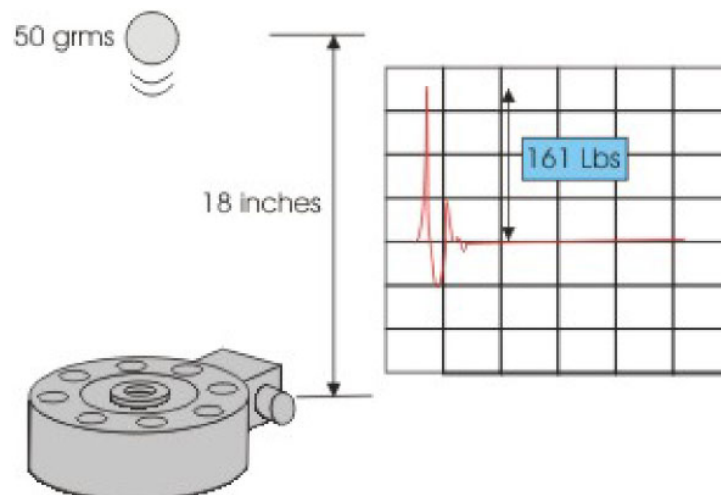

### HOW DOES A LOAD CELL WORK?

At the heart of a load cell is a strain gage. A strain gage is a device that changes resistance when it is deformed or stressed. The precise positioning of the gage, the mounting procedure, and the materials used all have a measurable effect on overall performance of the load cell. A strain gage is then cemented to the surface of a beam, diaphragm or column within a load cell. As the surface to which the gage is attached becomes strained, the fine wires of the strain gage wires expand or compress changing their resistance proportional to the applied load. In most strain gages four gages (or sometimes eight gages are used in the making of a load cell. Multiple strain gages are connected to create the four legs of a Wheatstonebridge configuration.



# Fragen und Antworten zu Kraftsensoren

## FAQ Load Cell

---

When an input voltage is applied to the bridge, the output becomes a voltage proportional to the load on the cell. The more load that is applied to the cell the more the bridge becomes unbalance and the larger the output. This output can be amplified and processed by signal conditioning or data acquisition equipment. In order to increase sensitivity of the wheatstone bridge all the arms are active and the four strain gages are arranged so that two arms of the bridge is in compression while the other two arms are in tension.

### WHAT LOAD RANGE SHOULD I CHOSE FOR A LOAD CELL?

The load range for load cell should obviously be a little more than the maximum load that the cell will encounter during normal use. Built into all Sensotec load cells is a 50% overload capability. That means that if a cell is rated to 100lbs that it can endure 150 lbs before permanent damage is done to the cell. The load cell will not hold specification between 100 and 150lbs. Above the overload range is a loading region where the cell becomes progressively damaged. The further into this region, the more damage that is done, until the cell eventually breaks. Cells that have been loaded beyond 150% are not always damaged so that they cannot be used but they will permanently have an electrical offset due to the 'set' that the load cell has now taken. This offset can be easily zeroed out by the load cell electronics. However because of this permanent damage the cell will have a lower future overload capability dependent on how much progressive damage was sustained. It is also important to take into consideration the dynamic loading on a load cell when specifying the loading range of a load cell. Dynamic loading can be catastrophic to a load cell. In this demonstration a 3/8 inch ball bearing weighing 2 ozs is dropped from 1ft onto a 100 load cell. The load cell experiences 140 lbs of load. If the ball bearing were to have been dropped from any higher the cell would have suffered irreparable damage.

### WHAT THINGS DO I NEED TO CONSIDER WHEN MOUNTING A LOAD CELL?

A load cell will only perform to its specification if it is mounted correctly. Many times the load cell is blamed for poor measurement performance when in fact the mounting arrangement is the source of the inaccuracy. In order of for the load cell to perform correctly the strain gauged element must be uniformly stressed when under load. In order for this to happen the following conditions should be met:

#### *Flat surface*

The mounting surface for the load cell should be flat, preferably a ground surface. This ensures that the load cell is strained evenly and that high spots do not induce an uneven loading on the load cell and therefore uneven stress levels.

#### *Hard, rigid surface*

The mounting surface for the load cell should be hard and rigid, This ensures that the surface does not distort or bend and twist under loading conditions. The loading stresses on the surface can be very severe particularly when miniature load cells are being used. Loads of 40,000 lbs per square inch are not uncommon. Once again if the surface is hard and rigid it will not distort and this ensures that the load cell is strained evenly and therefore experiences even stress levels.

#### *Level surface*

The surface should be level so that all the load is applied parallel to the main axis of the load cell. This ensures no cosine error is induced but also ensures that side loading does not create problems for the load cell, which will only have some degree of immunity.

Loading applied parallel to the main axis.

To ensure that the load cell only sees loads that are parallel to the main axis. In tension load cells rod end bearings can ensure that the load is always applied parallel to the main axis and in compression load cells load buttons fulfill a similar function.

