

- Messbereiche 15 ... 500 kN
- Messende Unterlegscheibe
- Rostbeständiger Edelstahl
- Schutzart IP65

- *Measuring range 15 ... 500 kN*
- *Force washer*
- *Stainless steel*
- *Level of protection IP65*

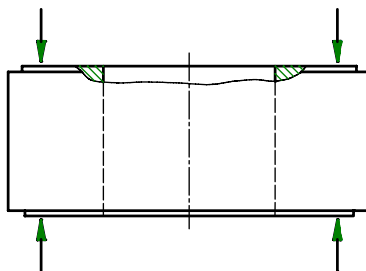

<b>Anschlussbelegung - Connection</b>	
Versorgung (-) - <i>Supply (-)</i>	Grün - <i>Green</i>
Versorgung (+) - <i>Supply (+)</i>	Braun - <i>Brown</i>
Signal (+) - <i>Signal (+)</i>	Gelb - <i>Yellow</i>
Signal (-) - <i>Signal (-)</i>	Weiß - <i>White</i>
Kontrolle (Option) - <i>Calibration control (option)</i>	Grau - <i>Grey</i>
Schirm - <i>Shield</i>	Schirm - <i>Shield</i>



Mechanische Abmessungen - Dimensions

K-180

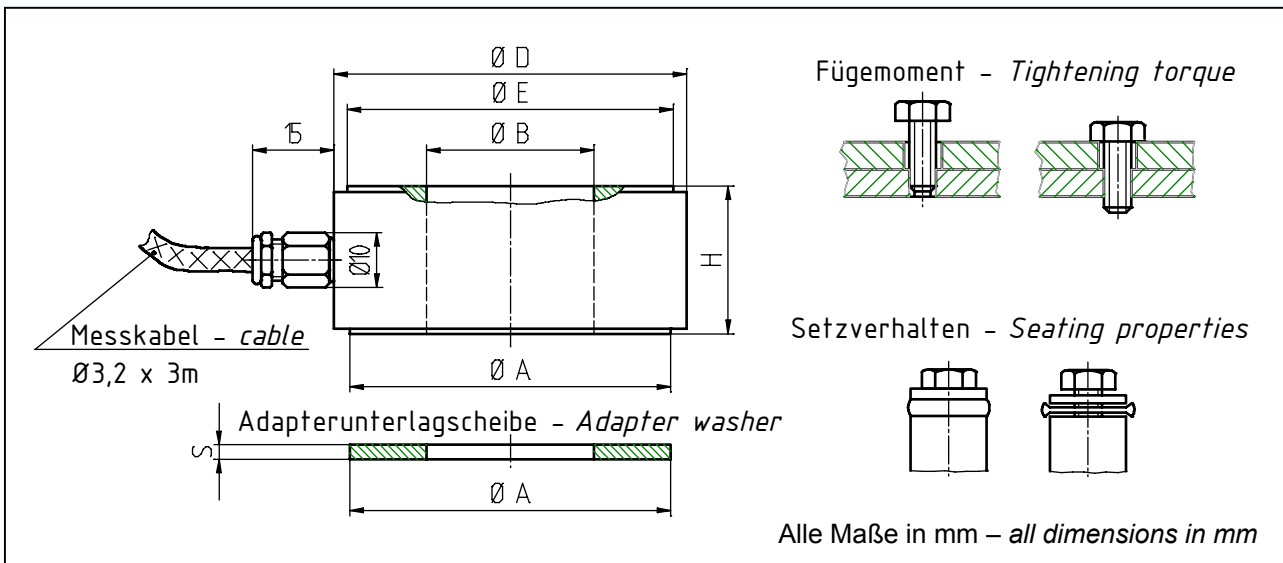

Messbereich - Measuring range [kN]	Für Schraube - For screw	Ø A	Ø B	Ø D	Ø E	H	S
15	M6	10,5	6,3	18	11	12	2
30	M8	15	8,3	22	16	12	2
60	M10	17	10,3	24	17,8	12	2
80	M12	22,5	12,3	28	22,5	15	2,5
120	M16	27,6	16,3	32	28	15	2,5
160	M20	37,5	20,3	46	38	15	3
350	M24	47	24,5	54	48	22	3
500	M30	59	30,8	65	60	27	3

TECHNISCHE DATEN - SPECIFICATIONS

Typ - Type	K-180	
Genauigkeitsklasse Druckkraft - Accuracy class compression force	S%	1
Genauigkeitsklasse bei Vorspannkraftmessung Accuracy class for preload force measurement	S%	3
Gebrauchslast - Service load	S%	130
Grenzlast - Limit load	S%	150
Bruchlast - Ultimate load	S%	>300
Max. dynam. Belastung - Max. dyn. load (DIN 50 100)	S%	70
Nennmessweg - Position feedback	mm	<0,1
Brückenwiderstand - Bridge resistance	Ω	350
Isolationswiderstand - Insulation resistance	Ω	>2*10 <sup>9</sup>
Speisespannung - Supply voltage	V	2 ... 6
Max. Speisespannung - Max. supply voltage	V	8
Nennkennwert (S) - Sensitivity (S)	mV/V	1,00
Kennwerttoleranz - Tolerance of sensitivity	S%	<±20
Temp.koeff. des Kennwertes - Temp. coeff. of sensitivity	S%/10K	±0,3
Temp.koeff. des Nullsignals - Temp. coeff. of zero signal	S%/10K	±0,3
Referenztemperatur - Reference temperature	°C	+23
Nenntemperaturbereich - Nominal temperature range	°C	0 ... +60
Gebrauchstemperaturbereich - Service temperature range	°C	-10 ... +70
Lagerungstemperaturbereich - Storage temperature range	°C	-30 ... +95
Veränderlichkeit - Repeatability	S%	0,3
Rel. Kriechen - Rel. creep	S%/30min	<±2
Werkstoff - Material	Rostbeständiger Edelstahl - Stainless steel	
Schutzart - Level of protection (DIN EN 60529)	IP65	
Elektrischer Anschluss - Electrical connection	3 m, freien Lötenden - 3 m, free soldered ends	

Optionen - Options

Kontrolle - Calibration control	S%	100
Nennkennwertabgleich (S) - Sensitivity calibration (S)	mV/V	1,00

Bei der Bestellung bitte die gewünschte Gewindegröße angeben! Please specify the required thread size at order!