

Typ MST (fester Sensoreinbau, *stiff sensor assembly*)

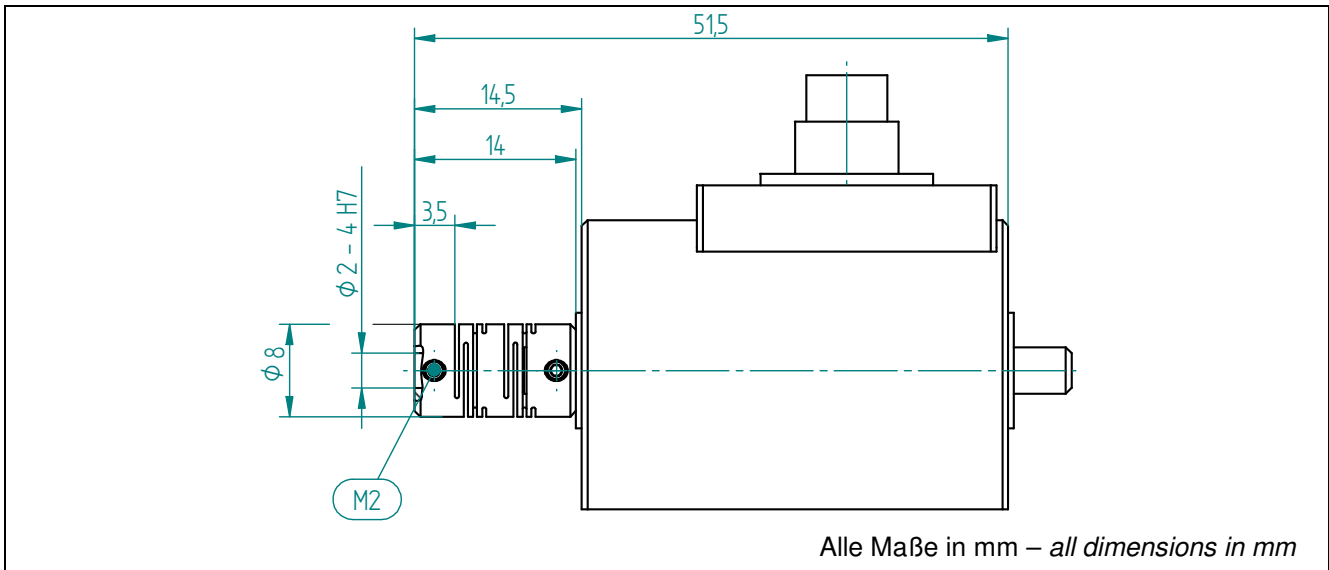

Messbereich - Measuring range [N·m]	Größe - Size	M <sub>A</sub> [N·m]
0,005 / 0,01 / 0,02	8	0,3

Typ MWS (fliegender Sensoreinbau, *floating sensor assembly*)

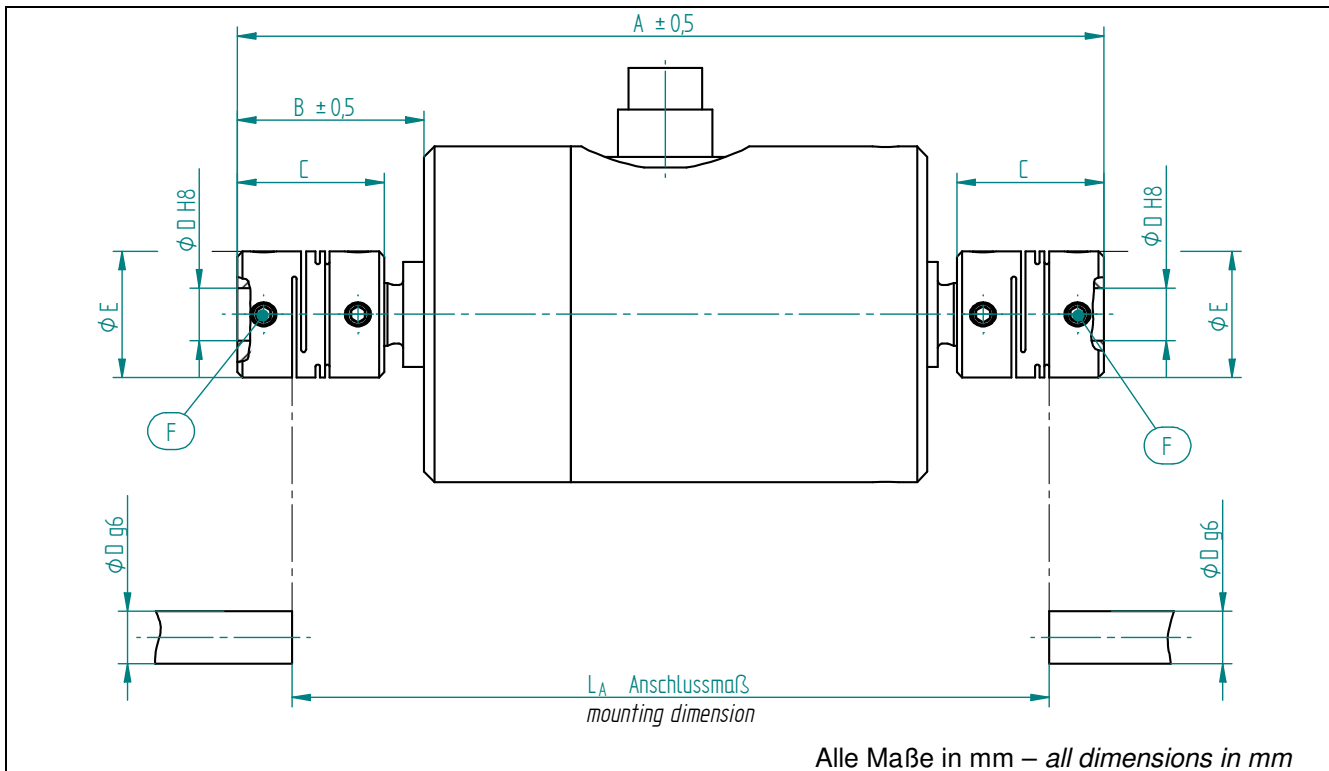

Messbereich - Measuring range [N·m]	Größe - Size	Abmessungen - Dimensions [mm]							M <sub>A</sub> [N·m]
		A	B	C	ØD	E	F	L <sub>A</sub>	
0,03 / 0,05	12	83	17	14	4 ... 6	12	2 x M2,5	72	0,5
0,1 / 0,2	16	108	29	18	4,5 ... 8	20	2 x M3	94	0,7
0,5	20	110	31	20	5 ... 10	20	2 x M3	95	0,7
1	25	116	34	25	5 ... 12	25	2 x M4	97	1,7
2	32	124	38	32	8 ... 16	32	2 x M4	99	1,7

Bei Bestellung bitte immer den gewünschten Ø D angeben! Please specify requested bore Ø D at order!

