

**DR2113**

- Aktiver Ausgang  $\pm 5\text{ V}$  - *Active output  $\pm 5\text{ V}$*
- Messrate 10 kSample - *Sample rate 10 kSample*

**DR2413**

- RS485-Schnittstelle - *RS485-Interface*
- Auto-Identifikation von: Messbereich, Serien- Nr., Kalibrierdatum - *Auto identification of: measuring range, serial number, date of calibration*
- Messrate 5 kSample - *Sample rate 5 kSample*



Diese Sensoren haben eine berührungslose und digitale Signalübertragung von Rotor zu Stator, also ohne Signalverfälschung und wartungsfrei.  
*These sensors have a contactless and digital signal transmission from rotor to stator, which means no signal falsification and maintenance-free.*



Artikel -Nr. Article-no. DR- 2113	Artikel- Nr. Article-no. DR- 2413	Messbereich Measuring range [N·m]	Vierkant Square	Max. Drehzahl Max. speed [min <sup>-1</sup> ]	Federkonstante Springrate [N·m/rad]	Massen- trägheits- moment Mass moment of inertia [kg·m <sup>2</sup> ]		Max. Axiallast Max. thrust load [N]
						Antriebsseite Drive side	Messseite Test side	
103806	104113	0,1	1/4"	3000	1,8·10 <sup>1</sup>	2,1·10 <sup>-6</sup>	2,3·10 <sup>-7</sup>	15
103804	104114	0,2		3000	1,8·10 <sup>1</sup>	2,1·10 <sup>-6</sup>	2,3·10 <sup>-7</sup>	20
103805	104115	0,5		3000	1,2·10 <sup>2</sup>	2,1·10 <sup>-6</sup>	2,3·10 <sup>-7</sup>	30
102604	104116	1		4000	1,2·10 <sup>2</sup>	2,1·10 <sup>-6</sup>	2,3·10 <sup>-7</sup>	40
103367	104117	2		4000	3,0·10 <sup>2</sup>	2,1·10 <sup>-6</sup>	2,4·10 <sup>-7</sup>	50
102605	104118	5		4000	3,5·10 <sup>2</sup>	2,1·10 <sup>-6</sup>	2,4·10 <sup>-7</sup>	50
102460	104119	10		4000	7,3·10 <sup>2</sup>	2,1·10 <sup>-6</sup>	2,7·10 <sup>-7</sup>	50
103798	104120	15		4000	7,3·10 <sup>2</sup>	2,1·10 <sup>-6</sup>	2,7·10 <sup>-7</sup>	100
102606	104121	20		4000	7,3·10 <sup>2</sup>	2,1·10 <sup>-6</sup>	2,7·10 <sup>-7</sup>	100
102459	104122	35		3/8"	3000	8,6·10 <sup>3</sup>	9,8·10 <sup>-6</sup>	1,1·10 <sup>-5</sup>
102193	104123	50	3000		1,0·10 <sup>4</sup>	9,9·10 <sup>-6</sup>	1,1·10 <sup>-5</sup>	1600
102272	104124	63	3000		1,1·10 <sup>4</sup>	1,0·10 <sup>-5</sup>	1,1·10 <sup>-5</sup>	1900
101882	104125	100	1/2"	2500	1,2·10 <sup>4</sup>	1,6·10 <sup>-5</sup>	1,1·10 <sup>-5</sup>	2600
102388	104126	160		2500	1,5·10 <sup>4</sup>	1,6·10 <sup>-5</sup>	1,2·10 <sup>-5</sup>	3200
102065	104127	200		2500	1,5·10 <sup>4</sup>	1,6·10 <sup>-5</sup>	1,2·10 <sup>-5</sup>	3200
103592	104128	300	3/4"	2500	8,8·10 <sup>4</sup>	9,8·10 <sup>-5</sup>	7,7·10 <sup>-5</sup>	5500
102969	104129	500		2500	8,8·10 <sup>4</sup>	9,8·10 <sup>-5</sup>	7,7·10 <sup>-5</sup>	7500
102273	104130	1000	1"	1500	1,3·10 <sup>5</sup>	2,1·10 <sup>-4</sup>	1,1·10 <sup>-4</sup>	10000
103799	104131	2000	1 1/2"	1000	2,1·10 <sup>5</sup>	3,5·10 <sup>-3</sup>	1,8·10 <sup>-3</sup>	18000
103800	109687	3000		1000	2,3·10 <sup>5</sup>	3,5·10 <sup>-3</sup>	1,8·10 <sup>-3</sup>	22500
103801	104132	5000		1000	2,7·10 <sup>5</sup>	3,5·10 <sup>-3</sup>	1,8·10 <sup>-3</sup>	32000

Bei der Bestellung bitte den gewünschten Messbereich angeben! *Please specify the required meas. range at order!*

**TECHNISCHE DATEN - SPECIFICATIONS**

Typ - Type		DR-2113	DR-2413
Genauigkeitsklasse - Accuracy class	% v. E. - f. s.	0,1	
Reproduzierbarkeit - Repeatability (DIN 1319)	%	±0,02	
Versorgung - Excitation voltage	V DC	12 ... 28	
Stromaufnahme - Current consumption	mA	<60	
Ausgangssignal - Output signal		0 ... ±5 V	±25000 digits
Belastbarkeit - Output current max.	mA	5 kurzschlussfest short circuit resist.	
Eingang Kontrollaufschaltung - Calibration control	V	L <2,0V; H >3,5V	per Software
Messrate - Sample rate	kSample	10	5
Referenztemperatur - Reference temperature	°C	+23	
Nenntemperaturbereich - Nominal temperature range	°C	+5 ... +45	
Gebrauchstemperaturbereich - Service temperature range	°C	0 ... +60	
Lagerungstemperaturbereich - Storage temperature range	°C	-10 ... +70	
Temp. koef. des Kennwertes - Temp. coeff. of sensitivity	% v. E./K - f. s./K	+0,01	
Temp. koef. des Nullsignals - Temp. coeff. of zero signal	% v. E./K - f. s./K	±0,02	
Gebrauchsdrehmoment (statisch) - Service torque (static)	% v. E. - f. s.	150	
Grenzdrehmoment (statisch) - Limit torque (static)	% v. E. - f. s.	200	
Bruchdrehmoment (statisch) - Ultimate torque (static)	% v. E. - f. s.	>300	
Schwingbreite - Bandwidth (DIN 50100)	%	70 (Spitze-Spitze) - (peak-peak)	
Schutzart - Level of protection (DIN EN 60529)		IP50	
Elektrischer Anschluss - Electrical connection		8-polig Serie 711 - 8-pin series 711 12-polig Serie 581 - 12-pin series 581	

**Optionen - Options**

Artikel- Nr. Article-no.	Bezeichnung - Description	
101560	Winkelmessung, 360 Impulse 2 x TTL 90° versetzt - Angle control 360 impulses, 2 traces, 90° displaced	Rechtsdrehung - CW-turn  CH A  CH B 
103562	Ausgangssignal - Output signal	V 0 ... ±10
105969	Elektrischer Anschluss - Electrical connection	12-polig Serie 581 - 12-pin series 581

**Anschlussbelegung - Pin connection**

8-polig - 8-pin	DR-2113			
Pin 1	Versorgung (+) - Excitation (+)		12 ... 28 V DC	
Pin 2	Versorgung (GND) - Excitation (GND)		0 V	
Pin 3	Signal (+) - Signal (+)		±5 V	
Pin 4	Signal (GND) - Signal (GND)		0	
Pin 5	Kontrolle - Calibration control		L <2,0 V; H >3,5 V	
Pin 6	Option Winkel A - Option angle A		TTL	
Pin 7	Option Winkel B - Option angle B		TTL	
Pin 8	NC		-	
12-polig - 12-pin	DR-2113		DR-2413	
Pin A	NC	-	NC	-
Pin B	Option Winkel B - Opt. Angle B	TTL	Option Winkel B - Opt. Angle B	TTL
Pin C	Sign. (+) - Signal (+)	±5 V	NC	-
Pin D	Signal (GND) - Signal (GND)	0 V	NC	-
Pin E	Vers. (GND) - Excitation (GND)	0 V	Vers. (GND) - Excitation (GND)	0 V
Pin F	Vers. (+) - Excitation (+)	12 ... 28 V DC	Vers. (+) - Excitation (+)	12 ... 28 V DC
Pin G	Option Winkel A - Opt. Angle A	TTL	Option Winkel A - Opt. Angle A	TTL
Pin H	NC	-	NC	-
Pin J	NC	-	RS485	RS485 (B)
Pin K	Kontrolle - Calibration control	L <2,0 V; H >3,5 V	NC	-
Pin L	NC	-	RS485	RS485 (A)
Pin M	Gehäuse - Housing		Gehäuse - Housing	



Mechanische Abmessungen - Dimensions

DR-2113; DR-2413

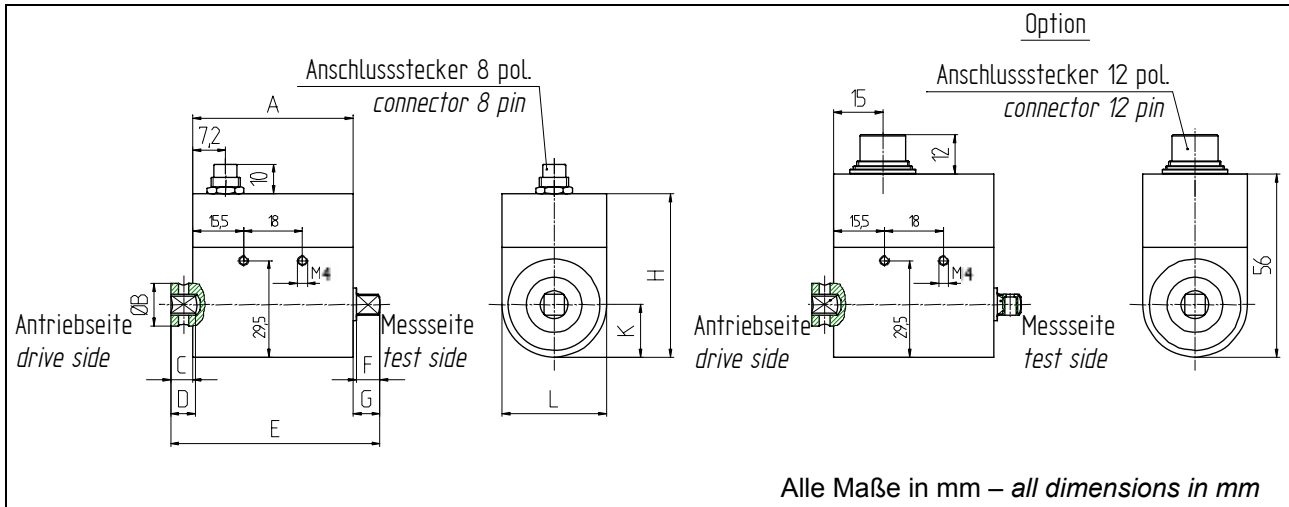

Messbereich - Measuring range [N·m]	Vierkant - Square	Abmessungen - Dimensions [mm]									
		A	B	C	D	E	F	G	H	L	K
0,1 / 0,2 / 0,5 / 1 / 2 / 5 / 10 / 15 / 20	1/4"	49	13	6,8	8	64	7,5	8,2	50	32	16

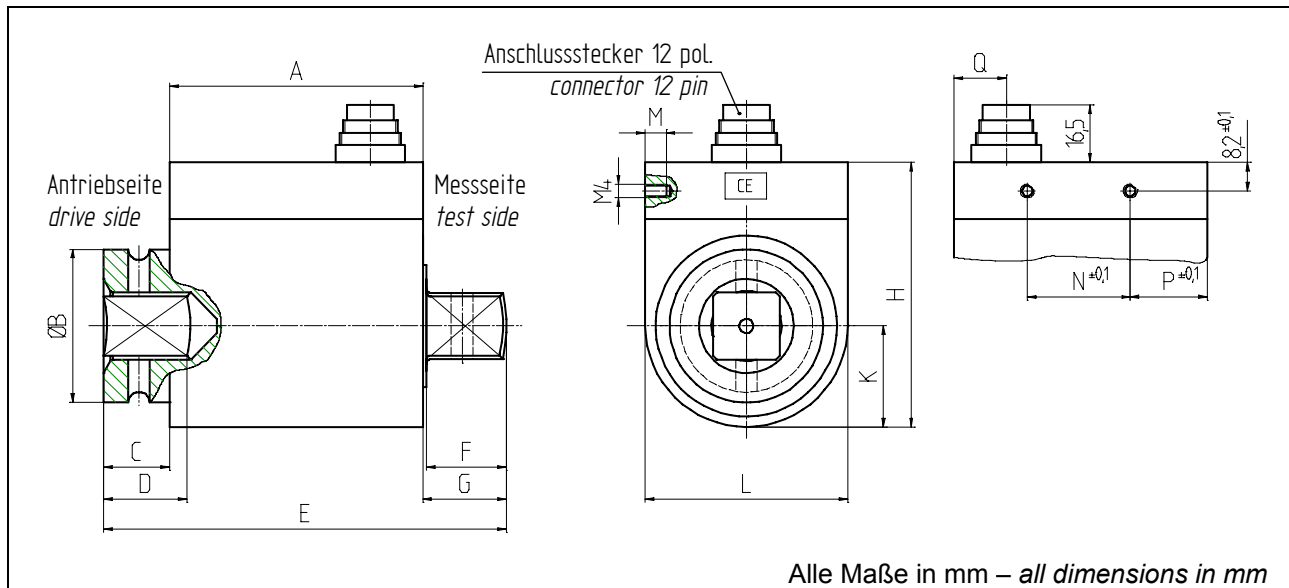

Messbereich - Measuring range [N·m]	Vierkant - Square	Abmessungen - Dimensions [mm]													
		A	B	C	D	E	F	G	H	L	K	M	N	P	Q
35 / 50 / 63	3/8"	71,5	22	11	11,2	94,5	10,7	12	59	40	20	5	41,5	15	12
100 / 160 / 200	1/2"	71,5	29,8	13	15,9	100,5	15,4	16	59	40	20	5	41,5	15	12
300 / 500	3/4"	72,5	44	19	23,9	115,5	22,9	24	76	58	29	6	29,5	22	15
1000	1"	72,5	54	29	28,6	130,5	27,6	29	76	58	29	6	29,5	22	15

Mechanische Abmessungen - *Dimensions*

DR-2113; DR-2413

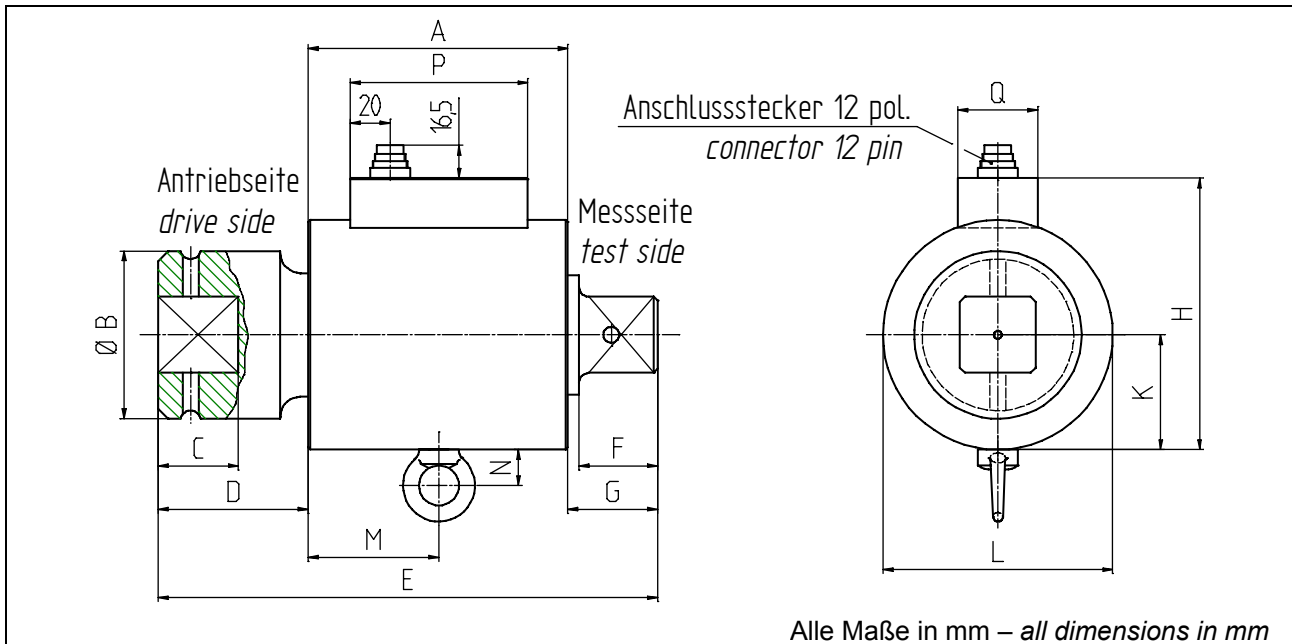

Alle Maße in mm – all dimensions in mm

Messbereich - Measuring range [N·m]	Vierkant - Square	Abmessungen - <i>Dimensions</i> [mm]													
		A	B	C	D	E	F	G	H	L	K	M	N	P	Q
2000 / 3000 / 5000	1 1/2"	130	84	40	75	250	39	45	136	115	57,5	65,5	18	89	40