

- Mit integrierter Drehzahl, Drehwinkelmessung - *integrated speed angle control*
- Beidseitig mit zylindrischer Welle - *both shaft ends with keyway*



Messbereich <i>nominal torque</i> [Nm]	Nenn- kennwert <i>sensitivity</i> [mV/V]	max. Dauer- drehzahl <i>continuous max speed</i> [min <sup>-1</sup> ]	Feder- konstante <i>springrate</i> [Nm/rad]	max Querlast <i>max lateral load</i> [N]	Massen- trägheitsmoment <i>moment of inertia</i> J in [kg m <sup>2</sup> ] Antriebsseite <i>drive side</i>	Gewicht <i>weight</i> [kg]
1	0,5	2000	2,3·10 <sup>2</sup>	4	3,3·10 <sup>-6</sup>	0,5
2	0,5	2000	2,3·10 <sup>2</sup>	5	3,3·10 <sup>-6</sup>	0,5
5	2	2000	2,9·10 <sup>2</sup>	7	3,3·10 <sup>-6</sup>	0,5
10	2	2000	5,6·10 <sup>2</sup>	7,5	1,1·10 <sup>-5</sup>	0,5
20	2	1500	1,6·10 <sup>3</sup>	12	1,1·10 <sup>-5</sup>	0,6
50	2	1500	4,1·10 <sup>3</sup>	28	1,1·10 <sup>-5</sup>	0,6
100	2	1500	7,9·10 <sup>3</sup>	65	1,3·10 <sup>-5</sup>	0,6
200	2	1000	2,8·10 <sup>4</sup>	80	1,0·10 <sup>-4</sup>	1,3
500	2	1000	5,3·10 <sup>4</sup>	200	1,0·10 <sup>-4</sup>	1,3



Eine kurzzeitige Überschreitung der Maximaldrehzahl um Faktor 1,5 ist möglich

Grenzspezifikation:  $t_{max} \leq 1 \text{ min}$  bei 50% ED

*A short time overstep of the maximum speed is possible by a factor 1,5*

*worst case:  $t_{max} \leq 1 \text{ min}$  at 50% on periode.*

**TECHNISCHE DATEN - specifications**

TYP - type		DR-20
Genauigkeitsklasse - accuracy class	% v.E	0,1
Kennwerttoleranz - tolerance of sensitivity	%	±0,1
Reproduzierbarkeit n. DIN 1319 - nonrepeatability	%	±0,05
Speisespannung - excitation voltage	V	2 ... 12
max Speisespannung - max excitation voltage	V	15
Speisespannung Winkel - excitation voltage angle	v	5
Impulse / Umdrehung - Imp. / Rotation		360
Spuren 90° versetzt - channel 90° (Quadrature)		2
Pegel - Signal	V	5 (TTL)
Rechtsdrehung - CW - turn		
CH A  CH B 		
Brückenwiderstand - bridge resistance	Ω	350
Nenntemp.bereich - nominal temp. range	°C	+5 ... +50
Gebrauchstemp.bereich - service temp. range	°C	-10 ... +60
Verdrillwinkel bei Nennmoment - twist angle by nominal load	°	<0,5
Grenzmoment (statisch) - limit torque	% v.E.	130
Gebrauchsmoment - service torque	% v.E.	120
Bruchmoment (statisch) - ultimate torque	% v.E.	250
Standzeit der Bürsten ca. - durability of brushes	Umdr.-rev.	5x10 <sup>7</sup>
Schwingbreite (DIN 50100) - bandwidth	%	70 (Spitze - Spitze) - (top - top)
Schutzart - level of protection (DIN EN 60529)		IP 50
Anschlußstecker - connector		12 polig - 12-pin

**Anschlussbelegung - connection**

12-polig - 12-pin		
Pin A	Vers. (GND) DMS - excitation strain gauge	0V
Pin B	Vers. (+) DMS - excitation strain gauge	2...12 V
Pin C	Sign. (+) - signal	
Pin D	Sign. (-) - signal	
Pin E	Vers. Winkel - excitation angle	0V
Pin F	Vers. Winkel - excitation angle	+5V
Pin G	Winkel A (TTL) - angle A (TTL)	
Pin H	Winkel B (TTL) - angle B (TTL)	
Pin J	Winkel - angle	0V
Pin K	Kontrolle - calibration control	(Option - option)
Pin L	NC	
Pin M	Schirm - shield	

Mechanische Abmessungen – dimensions

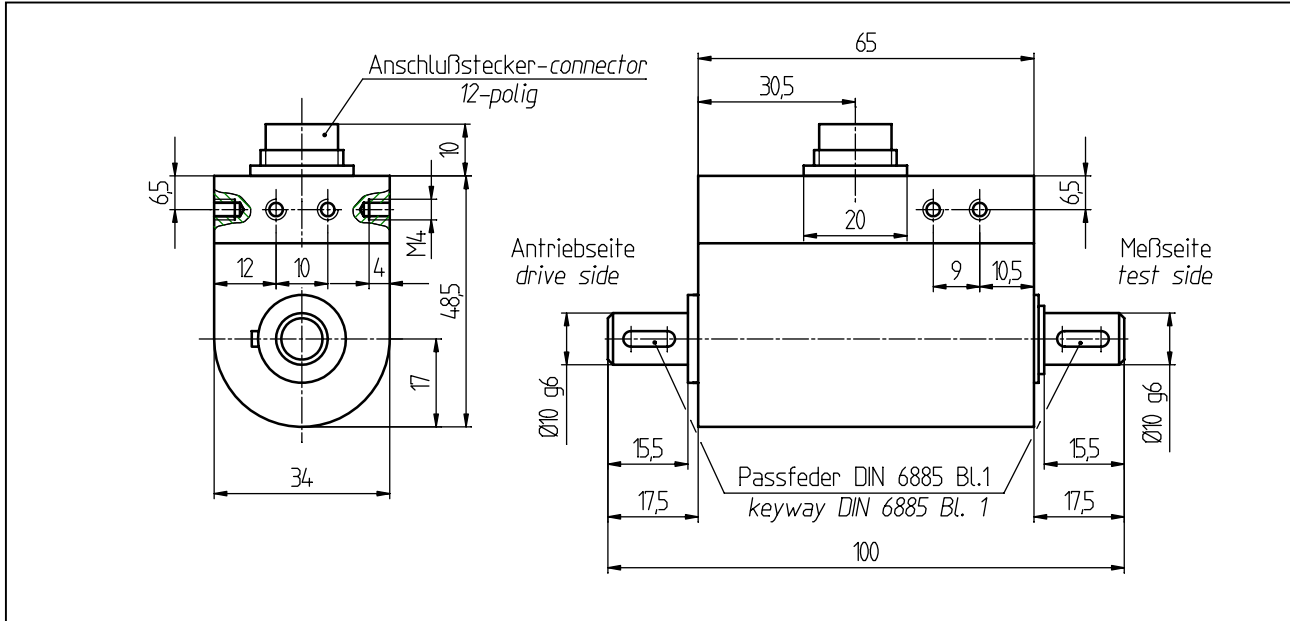

<b>Messbereich - nominal torque [Nm]</b>
0...10

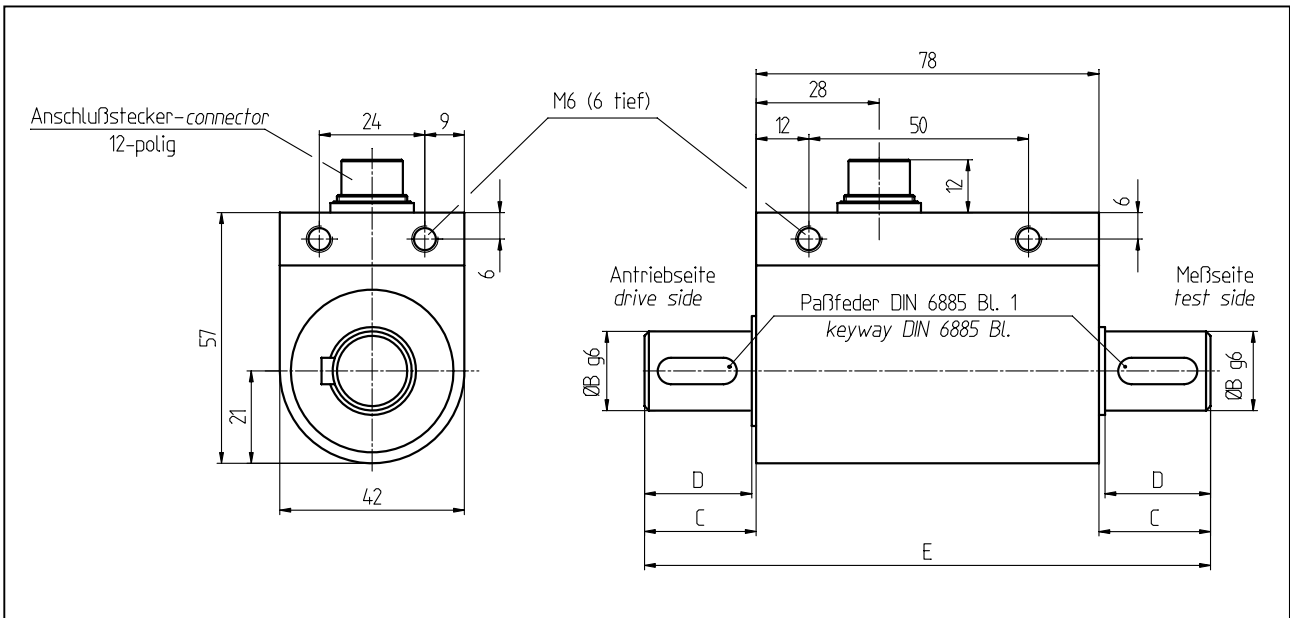

Messbereich nominal torque [Nm]	Abmessungen - dimensions [mm]			
	B	C	D	E
0...50	15	21	20	120
0...100	18	25	24	128

**Mechanische Abmessungen – dimensions**

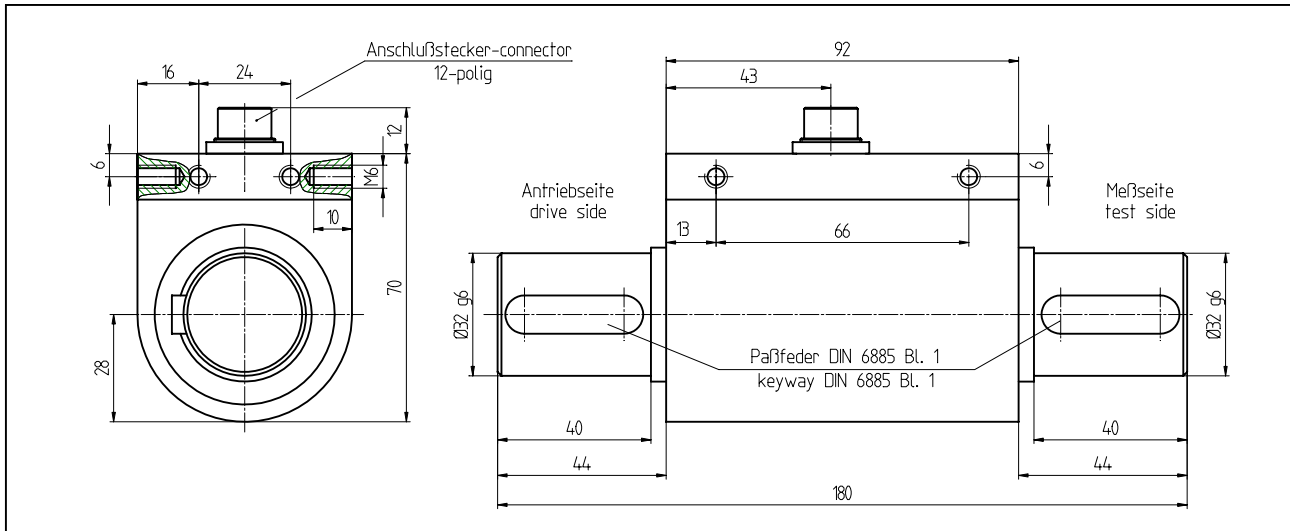

<b>Messbereich - nominal torque [Nm]</b>
0...500