

Temperature measurement and calibration: What every instrument technician should know

Application Note

Introduction

Temperature may be the most commonly measured physical parameter. Yet there have never been so many ways to measure it as there are today. With so many options it's natural to have a few questions. How do I measure temperature? How accurate is my measurement? What temperature range is required? What type of device best measures temperature? Does my instrument require certification?

These are very common questions when confronted with the need to measure temperature. A variety of measurement devices may be used for temperature; liquid-in-glass thermometers (LIG), thermocouples (TCs), thermistors, resistance temperature detectors (RTDs), platinum resistance thermometers (PRTs) and standard platinum resistance thermometers (SPRTs). This application note focuses on electronic temperature measurements, and helps clarify the answers to some of these nagging questions. More information on these subjects is available at www.fluke.com.

How do I measure temperature?

After inserting a temperature sensor into the area to be measured, it takes time before the temperature reading is stabilized. For the thermometer to stabilize at the correct temperature, the probe must be sufficiently immersed. Some thermometers require more immersion depth than others. Most precision thermometers

require four to six inches when inserted into a liquid or snug fitting well, depending on the diameter of the probe. Best results in terms of accuracy and stabilization time occur when the probe can be inserted into a stirred liquid. Air pockets between probes and solid surfaces lead to longer stabilization times and require more immersion than would be required in a liquid. Specialized thermometers are needed for measuring temperatures on surfaces and for situations where the probe cable will be exposed to extreme temperatures.

Often devices that measure and display temperature need to be verified or calibrated against a reference thermometer. Accuracy is improved when the distance between the two thermometers is reduced. A best practice is to align the centers of the sensing elements of the reference thermometer and the device under test. Be aware that the location of the center of the sensor depends on the sensor type and model (i.e. PRT, thermocouple, bimetallic).

A common method of calibrating temperature sensors is to remove them from where they are installed and place them in a dry-well calibrator or a Micro-Bath. These calibrators provide a stable temperature environment over a range of temperatures to compare the thermometer under test to the calibrator display or to a reference thermometer for more accuracy. Alternatively, temperature sensors may be calibrated or verified without



removing them from their installed location. Usually this is done by inserting a reference thermometer into a thermowell, immersion well, or thermometer pocket installed next to the thermometer to be tested. In other cases the sensing element of the reference thermometer must be placed inside of the freezer, oven, or environmental chamber being verified, calibrated or adjusted.

In these cases it is often necessary to record data over a period of time such as a few hours to verify performance. Statistics such as average value, maximum and minimum, or standard deviation are sometimes recorded.

Testing the energy performance of steam systems, cooling towers, heat exchangers, and refrigeration systems, turbines, and internal and external combustion engines requires measuring differences between inlet and outlet temperatures. Sometimes these measurements have to be made from outside the pipe using thermocouples, thin-film sensors, or infrared temperature measurements. However, the best accuracy will be achieved when a thermowell has been properly installed in both the inlet and outlet pipes so that a probe can be inserted and sufficiently immersed. Because pipe diameters are sometimes a limiting factor for immersion, the best location for a thermowell is at an elbow in the piping so that the probe can be inserted parallel to fluid flow with as much immersion depth as needed.

How much accuracy is needed?

Decisions about accuracy should be made carefully. Inaccuracy leads to mistakes and mistakes cost money. Mistakes may lead to down time, excessive energy costs, high product defect rates, safety hazards, and public health threats.

| TUR | Accepted | False Accept | Rejected | False Reject |
|-----|----------|--------------|----------|--------------|
| 1:1 | 843 | 17 | 157 | 128 |
| 2:1 | 925 | 12 | 75 | 41 |
| 3:1 | 941 | 9 | 59 | 22 |
| 4:1 | 947 | 8 | 53 | 15 |

Table 1. What-if table summarizing false accept and false reject risk for a hypothetical scenario of 1000 instruments that are truly 95 % in tolerance. A normal distribution without guard-banding is assumed.

Thermometers are specified by design engineers for temperature monitoring or control. These specifications should include the accuracy of the thermometers. A design engineer, quality engineer or metrologist should also specify the calibration requirements. However, it is not uncommon for instrument technicians to receive a calibration job and little or no information about calibration requirements.

A common calibration strategy is to reduce mistakes by keeping the uncertainty of the calibration standards to a low percentage of the accuracy of the thermometer under test. This percentage is usually described as a Test Uncertainty Ratio (TUR). For example, the 4:1 TUR used by the military and other industries keeps the collective uncertainty of the calibration standards to 25 % of the thermometer under test accuracy. For comparison, a TUR of 2:1 means that the uncertainty is 50 % of the thermometer accuracy, and if the reference thermometer has the

same accuracy as the thermometer under test, then the TUR is 1:1. The latter TUR is never recommended for calibration and would produce unreliable results.

With a more accurate calibration standard you can identify more actual out-of-tolerance field devices. Table 1 illustrates the expected frequency of making mistakes at various TURs. Table 1 is based on a scenario where 950 of 1,000 instruments are truly in tolerance. For example, if all 1,000 are calibrated with a 2:1 TUR then we expect that 926 will be found in tolerance (accepted), 12 of which are truly out of tolerance (false accept). Of the 74 expected to be rejected, 41 are expected to be truly in tolerance (false reject). The cost incurred for each of those falsely rejected instruments could range from \$50/each for a calibration house to \$10,000/each in down time in the chemical process industry.

| | Temperature range | Accuracy | Cost |
|------------------------------------------------|------------------------------|------------------|------------|
| Noble-metal thermocouples (Special tolerances) | R, S: -50 °C to 1760 °C | > ± 0.6 °C | Med |
| Base-metal thermocouples (Special tolerances) | B: 0 °C to 1820 °C | ± 0.25 % | Low |
| | E: -270 °C to 1000 °C | > ± 1 °C | Low |
| | J: -210 °C to 1200 °C | > ± 1.1 °C | Low |
| | K: -270 °C to 1370 °C | > ± 1.1 °C | Low |
| | N: -270 °C to 1300 °C | > ± 1.1 °C | Low |
| | T: -270 °C to 400 °C | > ± 0.5 °C | Low |
| PRTs and SPRTs | Industrial: -80 °C to 480 °C | ± 0.05 - 0.1 °C | Low - Med |
| | Reference: -200 °C to 660 °C | ±0.001 - 0.02 °C | Med - High |
| | High temp: 0 °C to 1000 °C | ±0.01 - 0.02 °C | Med - High |
| Precision thermistors | 0 °C to 100 °C | ±0.002 °C | Med |

Table 2. Temperature sensor tradeoffs among temperature range, accuracy and cost. The most accurate sensors are the most expensive. Often accuracy is sacrificed for wider temperature range.

Thermometer probe types

There have never been as many temperature sensor (probe type) choices available for your measurements as there are today. With so many choices, the task can become time consuming and difficult without some help. The most important factors are temperature range, accuracy and cost. Table 2, on the previous page, illustrates the tradeoffs among these factors for several thermometer types.

Thermocouples (TCs)

Thermocouples are temperature sensors that measure temperature by generating a small voltage signal proportional to the temperature difference between the junctions of two dissimilar metals. One junction (the measurement junction) is typically encased in a sensor probe at the point of measurement; the other junction (the reference junction) is typically connected to the measuring instrument. The measurement instrument measures two things: the voltage signal and the reference junction temperature. From those two things the instrument computes the temperature at the measuring end of the probe. It is important to note that the voltage generated by the sensor

is not based on the absolute temperature of the measurement junction, but rather a temperature difference between the measurement junction and the reference junction.

Thermocouple types are distinguished by the metals used in each leg of the thermocouple. Noble metal thermocouples all contain platinum in one leg of the thermocouple and include Type S, Type R, Au/Pt, and Pt/Pd. Base metal thermocouples include Type B, Type E, Type J, Type K, Type N, and Type T. These thermocouples come in two accuracy classes: standard limits of error and special limits of error. The special limits of error thermocouples are the most accurate. Letter designated thermocouple tables are available from NIST on the web or in NIST monograph 175. A thermocouple voltage and sensitivity calculator is also available on the web at www.fluke.com.

Reference junction compensation is one of the most significant contributors to the accuracy of a thermocouple measurement. Thermocouple tables like those in NIST monograph 175 are based on a reference junction temperature of 0 °C. Although external reference junctions can be used to achieve this with an ice bath,

thermocouple wire is usually connected directly to the thermocouple readout binding posts at room temperature. Automatic reference junction compensation is needed to compensate for the deviation from 0 °C. A thermistor bead is usually used to measure the temperature of the junction. The readout measures the resistance of the thermistor and calculates a correction for the thermocouple temperature. In Figure 2, thermocouple wire meets with copper wire at the binding posts of the meter forming the reference junction (J). The temperature in the region surrounding the binding posts (TJ) is usually measured by a thermistor. Automatic reference junction compensation is accomplished by measuring the difference from 0 °C at the binding posts (TJ) and compensating for it digitally. The accuracy of this measurement has a significant impact on the accuracy of the overall temperature measurement.

Resistance based temperature measurement

An RTD is a temperature sensing element that relates temperature to its own resistance. There are several kinds of RTDs. RTD sensing elements include coils of

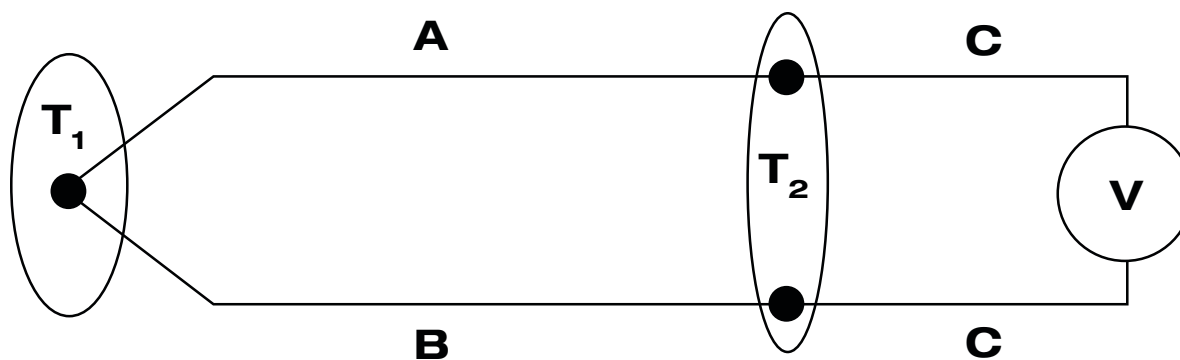

Figure 1. Model of a thermocouple circuit where A and B are dissimilar thermocouple wire, T1 represents the temperature at the measurement junction, and T2 represents the temperature at the reference junction. The absolute temperature at T1 does not produce the voltage measured at V; rather, the temperature difference between T1 and T2 produces the measured voltage.

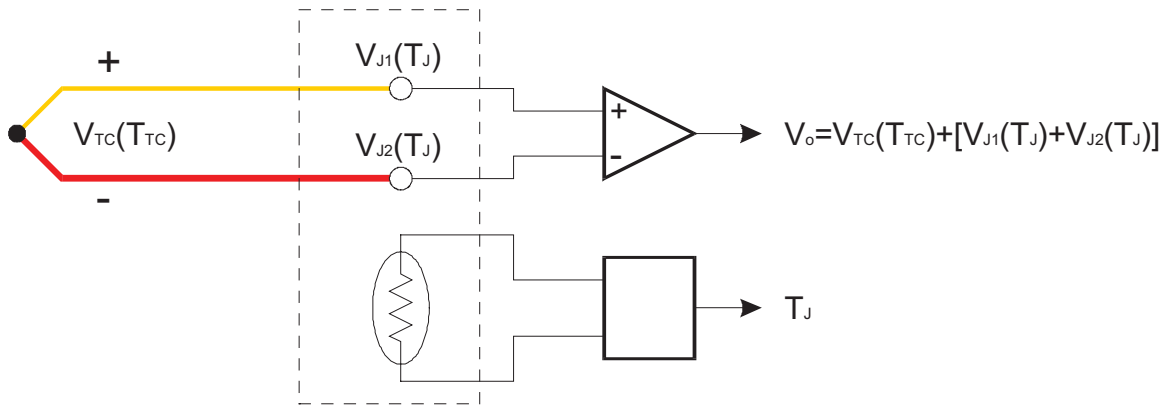

Figure 2. Reference junction compensation is one of the most significant contributors to the accuracy of a thermocouple measurement. Caution: some manufacturers may not advertise this important part of their accuracy.

platinum wire (PRT), nickel wire, copper wire, thin films and more. Another resistance based sensor is the thermistor which is made of semi-conducting material. Figure 3 illustrates a simple 2-wire measurement circuit. The sensing element is labeled R_T . The lead-wires have finite resistances labeled R_{L1} and R_{L2} .

When current passes through the sensor, the environment is going to get a little warmer because of power dissipation. The more resistance or current there is, the more power gets dissipated ($P=I^2R$). The self-heating will be higher in air because the heat will not flow away as efficiently as it would in a stirred fluid. Self-heating errors can be minimized by using the same level of current used during calibration. Using the correct current is particularly important in thermistors because they can have very large resistances causing greater self-heating.

Current reversal is a very effective technique used in resistance measurements to eliminate errors associated with thermal EMFs. Thermal EMFs are unwanted voltages in a resistance measurement circuit caused by the same principle that produces a voltage in thermocouples. The measurement is made with the current flowing in one direction and then again with the current flowing in the other direction. Thermoelectric EMFs are removed by averaging

the results of both sets of measurements. This technique used by many modern instruments improves measurement stability and reduces significant errors that are common in other instruments.



Platinum resistance thermometers

A platinum resistance thermometer (PRT) element contains coils of highly-pure platinum wire. The resistance of a PRT element varies more linearly with temperature than any other temperature sensor. A Standard Platinum Resistance Thermometer (SPRT) is the most accurate temperature sensor available and is used in National Standards Laboratories and in industry for traceability to the International Temperature Scale of 1990 (ITS-90). The full text of the ITS-90 is available at www.bipm.org.

Temperature measurement with a PRT requires correlating the resistance of the sensing element with temperature using the correct equations and coefficients. Fortunately, most thermometer readout devices have support for these equations, so the calculations are handled automatically. Examples include ITS-90 equations,

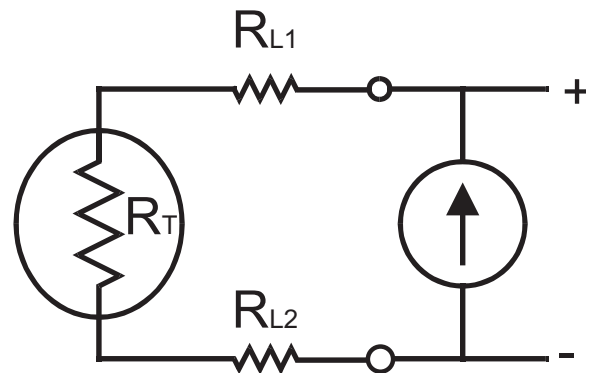

Figure 3. Current is passed through the sensing element to produce a voltage measured by a meter. Lead-wire resistance in two-wire measurements causes potentially large temperature measurement errors. Other types of resistance measurements include three-wire and four-wire resistance measurements. Four-wire measurements are preferred in temperature applications because they eliminate lead wire resistance from the measurement.

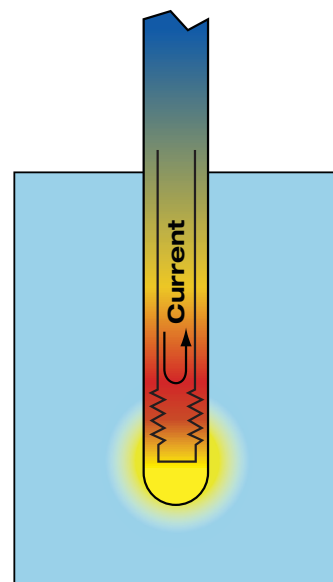

Figure 4. Current is required to measure resistance. Current that passes through a resistance dissipates power and generates heat, causing temperature errors.

Callendar Van Dusen (CVD) equations, and polynomial equations. Best performance with PRTs can usually be achieved with the ITS-90 equations. Older readouts and uncalibrated PRTs may use CVD equations.

The coefficients used with these equations are customized through calibration and can be found on individual calibration reports along with a table that describes the resistance vs temperature relationship. Some inexpensive PRTs used for industrial measurement are intended to operate even without calibration. Out of the box they should conform to a standard such as IEC 60751 or ASTM 1137. These standards specify values for the CVD coefficients and tolerances that depend on temperature. However, the accuracy of these probes can be significantly improved through calibration.

Thermistors

A thermistor element is made of semi-conducting material and has an electrical resistance that varies non-linearly with temperature. Thermistors are widely used because of their sensitivity, small size, ruggedness and low cost. Thermistor accuracy depends greatly on design and construction. Inexpensive thermistors are commonly used in electronics applications while precision thermistors are calibration standards rivaling the accuracy of SPRTs.

The resistance vs temperature relationship in thermistors is described by a few different polynomial equations. One form of the equations is used to calculate temperature T(R) and another form of the equation takes temperature as an input to calculate resistance R(T). The standard version of these equations take four coefficients, but the Steinhart-Hart version only requires three.

| Readout device | Requirements |
|----------------------|-------------------------------------------------------------------------------------------------------------------------|
| Thermocouple readout | Good accuracy from -10 mV to 100 mV Low noise floor Very low thermal EMFs Good reference junction compensation |
| PRT readout | Excellent accuracy from 0 Ω to 400 Ω Current reversal Four-wire resistance measurement 1 mA excitation current |
| Thermistor readout | Reasonable accuracy from 150 Ω and 500 kΩ Better accuracy required below 1000 Ω 2 μA to 10 μA excitation current |

Table 3. What to look for in electronic thermometer readouts.



Thermometer accuracy, repeatability, and resolution

Two important components of accuracy are repeatability and resolution. They should be considered along with other factors affecting accuracy. Repeatability refers to the consistency in values of repeated measurements. Regular calibration is helpful for establishing instrument repeatability. Another important method of verifying repeatability in thermometers is to measure periodically in an ice point or triple point of water cell and record the results.

Resolution on a digital thermometer is often user selectable. A digital thermometer should be chosen with sufficient resolution to achieve the desired accuracy; however, resolution is not the same thing as accuracy, it is merely a limiting factor in the accuracy. In a liquid and glass or dial thermometer, the resolution

may be the most important factor affecting the accuracy aside from calibration.

Accuracy specifications can be structured several ways. Specifications will usually be divided into ranges and may be given in base units of temperature, resistance or voltage. Simple specifications will either be a variable or fixed value, and complex specifications will be a combination of both. When variable type specifications are used, the allowed error increases when the magnitude of the reading increases. Calculations are required for a numeric result. Examples include percent of reading or parts per million (PPM). On the other hand, fixed value specifications remain constant over a range. Examples include percent of scale or span and numeric constants.

You can convert specifications in base units of resistance or voltage to temperature. The conversion depends on the sensitivity of the temperature sensor. For example, change temperature 1 °C and it will result in a 0.4 Ω change in resistance for a 100 Ω PRT and result in a 0.1 Ω change for a 25 Ω SPRT, but it may cause a 1000 Ω change in a thermistor. This means a one degree change in temperature may have a very big or very small impact on the change in resistance. Consequently, a meter with ± 1 Ω

accuracy will be most accurate for those sensors with the highest temperature sensitivity.

Each of the thermometers listed in Table 2 requires a digital readout. The best digital readout is going to be designed specifically for temperature measurement. Table 3 lists some of the requirements for good electronic thermometer readouts.

Reference junction compensation is one of the most significant contributors to the accuracy of a thermocouple measurement. Thermocouple tables are based on a reference junction temperature of 0 °C. Although external reference junctions can be used to achieve this with an ice bath, thermocouple wire is usually connected directly to the thermocouple readout binding posts at room temperature. Automatic reference junction compensation is needed to compensate for the deviation from 0 °C. A thermistor bead is usually used to measure the temperature of the junction. The readout measures the resistance of the thermistor and calculates a correction for the thermocouple temperature.

NIST and calibration

NIST is a National Metrology Institute (NMI) responsible for United States national standards. Metrology is the science of measurement and includes basic research, activities that ensure adequate functioning of measurement instruments used in industry, and also measurements that ensure economic transparency, public health, and safety. Traceability to NIST or another NMI is established through calibration. The three main reasons for having an instrument calibrated are:

1. To ensure readings from an instrument are consistent with other measurements
2. To determine the accuracy of the instrument readings
3. To establish the reliability of the instrument

To ensure that temperature measurements around the world are consistent each country has adopted the ITS-90, a temperature scale defined by the BIPM (International Bureau of Weights and Measures). Instrument accuracy is determined by comparison to measurement standards of higher accuracy. These measurements are part of a chain of comparisons that extend from end user measurements in the field to secondary calibration laboratories and then all the way to national (i.e. NIST) and international standards.

In addition to traceability, sometimes calibration customers have an additional requirement for accreditation. Accreditation provides assurance that an appropriate quality program is in place and that training and procedures meet the technical requirements for the calibration service provided. A logo appearing on accredited calibration certificates distinguishes them from other calibration certificates. There are many accreditation programs available. NIST sponsors the National Voluntary Laboratory Accreditation Program (NVLAP).

Maintain your standards

Maintenance of calibrated equipment is an important part of quality assurance. There is no guarantee that a calibrated thermometer will remain calibrated over time. Changes in the temperature relationship of used thermometers over time need to be corrected by calibration at regular intervals. When thermometers are found repeatedly out of tolerance remedial actions need to take place, such as shortening the calibration interval or replacing the thermometer. It is a good idea to keep records and monitor certified thermometers between calibrations using an appropriate method such as an ice bath, or triple point of water cell. This will limit or prevent expensive consequences should a certified thermometer be found significantly out of tolerance.



What to look for in a temperature calibration equipment solution provider

When choosing calibration equipment solution providers there are many factors to be considered. Here are a few of them.

A complete solution: Make sure that the company you choose has a complete range of products so that your options can be based on your needs and not just what they have available. If you're considering using automation software in the future to improve productivity you should plan to stick with one supplier because the manufacturer's software will likely only work with their own equipment.

Experience: You probably don't have time to be an expert in temperature calibration along with everything else you do. It's important to get help from the experts, so look for a company that specializes in temperature calibration so you won't have to.

Support: Expertise is great, but make sure you have access to the experts. You are in good hands if they answer their phones, treat you respectfully and get answers to all your questions. You'll also want to make sure they can resolve any equipment problems for you quickly. Ask about service turnaround times. If your equipment must be sent to a different continent for repairs you could be in for some serious delays.

Accreditation: Even if you don't have a specific requirement for accreditation it makes sense to work with a company that has an accredited laboratory. Here's why. An accredited laboratory has been inspected very carefully to make sure they have the organizational capability to do what they say they do. In the case of NVLAP accreditation the laboratory has passed a technical assessment performed by experts from NIST.

A guarantee: Calibration is all about confidence. First, make sure accuracy specifications are provided. Second, make sure those specifications are guaranteed. The last thing you need is to wind up with a piece of equipment taking up space that doesn't perform as promised.

Fluke Calibration

Fluke Calibration provides the broadest range available of calibrators, standards, software, service, training and support solutions. Our customers work in electrical, temperature, pressure and flow calibration laboratories around the globe, as well as in manufacturing test, research and development, and service.

The Fluke Calibration temperature calibration division makes everything needed for calibrating temperature sensors, from constant temperature baths and dry-well calibrators with unmatched stability to primary temperature standards used in national metrology institutes around the world. For precision thermometry, Fluke Calibration thermometer readouts and probes are exceptionally accurate and easy to use, and our temperature and humidity data logger eliminates the need for paper chart recorders. In addition Fluke Calibration also offers temperature calibration training courses from experienced instructors and expert service from its NVLAP-accredited laboratory (lab code 200348-0).

Fluke Calibration.

Precision, performance, confidence.™

| |
|--------------------|
| Electrical |
| RF |
| Temperature |
| Pressure |
| Flow |
| Software |

Fluke Calibration
PO Box 9090, Everett, WA 98206 U.S.A.

Fluke Europe B.V.
PO Box 1186, 5602 BD
Eindhoven, The Netherlands

For more information call:
In the U.S.A. (877) 355-3225 or
Fax (425) 446-5116
In Europe/M-East/Africa +31 (0) 40 2675 200 or
Fax +31 (0) 40 2675 222
In Canada (800)-36-FLUKE or
Fax (905) 890-6866
From other countries +1 (425) 446-5500 or
Fax +1 (425) 446-5116
Web access: <http://www.fluke.com>

©2011 Fluke Corporation.
Specifications subject to change without notice.
Printed in U.S.A. 3/2011 3996588A A-EN-N Pub-Id 11798-eng

Modification of this document is not permitted without written permission from Fluke Corporation.



TRANSMETRA GmbH
Rundbuckstrasse 2 · CH-8212 Neuhausen a. Rhf.
Tel. +41 (0)52 624 86 26 · Fax +41 (0)52 624 86 11
www.transmetra.ch · E-Mail: info@transmetra.ch